



**Continental Disc®  
Corporation**

## Preparation and Installation of the ZAP Rupture Disc Assembly

### WARNING

USER SHOULD READ AND THOROUGHLY UNDERSTAND THESE INSTRUCTIONS BEFORE INSTALLING RUPTURE DISC. THESE INSTRUCTIONS DO NOT PURPORT TO ADDRESS ALL OF THE SAFETY FACTORS ASSOCIATED WITH THE RUPTURE DISC'S USE IN SERVICE. IT IS THE RESPONSIBILITY OF THE USER TO ESTABLISH APPROPRIATE SAFETY, HEALTH, AND TRAINING MEASURES FOR THEIR PERSONNEL INSTALLING, SERVICING, OR WORKING IN AN AREA WHERE RUPTURE DISC ASSEMBLIES ARE IN USE. SERVICE AND/OR MAINTENANCE ON OR AROUND THE RUPTURE DISC DEVICE MUST NOT BE PERFORMED WHILE THE DEVICE IS SUBJECTED TO OPERATING PRESSURES AND/OR TEMPERATURES.

IT IS THE USER'S SOLE RESPONSIBILITY FOR DESIGN AND PLACEMENT OF RUPTURE DISCS WITHIN THEIR FACILITY AND UPON THE EQUIPMENT UPON WHICH THE RUPTURE DISC OF USER'S SELECTION IS TO BE LOCATED. IT IS USER'S SOLE RESPONSIBILITY FOR THE DESIGN OF ADEQUATE VENTING AND INSTALLATION OF ADEQUATE VENT PIPING OR DIRECTIONAL FLOW AFTER RUPTURE OCCURS WITH THE RUPTURE DISC AS INTENDED. WHEN SIZE IS SPECIFIED, CONTINENTAL DISC CORPORATION ASSUMES THAT ADEQUATE PROVISIONS HAVE BEEN MADE BY PURCHASER FOR PROPER VENTING OF A SYSTEM TO RELIEVE THE SPECIFIC PRESSURE. LOCATE RUPTURE DISC WHERE PEOPLE OR PROPERTY WILL NOT BE EXPOSED TO THE SYSTEM DISCHARGE IN CASE OF RUPTURE. VENT TOXIC OR FLAMMABLE FUMES OR LIQUIDS TO A SAFE LOCATION TO PREVENT PERSONAL INJURY OR PROPERTY DAMAGE.

IT IS THE USER'S SOLE RESPONSIBILITY TO SPECIFY THE BURST PRESSURE RATING OF A RUPTURE DISC AT A COINCIDENT TEMPERATURE AT WHICH THE RUPTURE DISC IS TO BE USED. A RUPTURE DISC IS A TEMPERATURE SENSITIVE DEVICE. THE BURST PRESSURE OF THE RUPTURE DISC IS DIRECTLY AFFECTED BY ITS EXPOSURE TO THE COINCIDENT TEMPERATURE. GENERALLY, AS THE TEMPERATURE AT THE RUPTURE DISC INCREASES, THE BURST PRESSURE DECREASES; INVERSELY, AS THE TEMPERATURE AT THE RUPTURE DISC DECREASES, THE BURST PRESSURE MAY INCREASE. FAILURE TO PROPERLY UTILIZE A RUPTURE DISC AT THE SPECIFIED COINCIDENT TEMPERATURE COULD CAUSE PREMATURE FAILURE OR OVERPRESSURIZATION OF A SYSTEM.

THE INSTANTANEOUS RELEASE OF PRESSURE FROM THE RUPTURE DISC CAN CREATE VIOLENT NOISES DUE TO THE DISCHARGE AT SONIC VELOCITY. IT IS THE USER'S SOLE RESPONSIBILITY TO PROTECT AGAINST HEARING DAMAGE TO ANY BYSTANDERS.

RUPTURE DISCS AND TAGS ARE MADE OF METAL FOILS OF VARYING THICKNESS. THE METAL EDGES MAY BE SHARP. PERSONNEL INSTALLING OR EXAMINING THE RUPTURE DISCS SHOULD PROTECT AGAINST CUTS OR INJURY WHEN HANDLING THE RUPTURE DISC. DO NOT LIFT A RUPTURE DISC BY ITS ATTACHED TAG.

PARTICLES MAY BE DISCHARGED WHEN THE RUPTURE DISC RUPTURES. THESE PARTICLES MAY BE PART OF THE RUPTURE DISC ITSELF, OR OTHER ENVIRONMENTAL MATTER IN THE SYSTEM. IT IS THE USER'S SOLE RESPONSIBILITY TO ASSURE THAT THESE PARTICLES ARE DIRECTED TO A SAFE AREA TO PREVENT PERSONAL INJURY OR PROPERTY DAMAGE.

THERE IS NO GUARANTEE OF RUPTURE DISC LIFE. SUCH LIFE SPAN IS AFFECTED BY CORROSION, CREEP AND FATIGUE, AND PHYSICAL DAMAGE. THESE CONDITIONS WILL DERATE THE RUPTURE DISC TO A LOWER SET PRESSURE. THE CUSTOMER AND/OR USER SHOULD BE PREPARED TO HANDLE PREMATURE FAILURE OF THE RUPTURE DISC. THE MEDIA OR OTHER ENVIRONMENTAL CONDITIONS SHOULD NOT ALLOW ANY BUILDUP OR SOLIDIFICATION OF MEDIA TO OCCUR ON A RUPTURE DISC. THIS MAY INCREASE THE PRESSURE SETTING OF THE RUPTURE DISC.

CUSTOMER AND/OR ITS INSTALLER SHALL BE SOLELY RESPONSIBLE FOR THE PROPER INSTALLATION OF SELLER'S HOLDERS AND RUPTURE DISCS INTO A SYSTEM. CUSTOMER AND/OR ITS INSTALLER SHALL BE SOLELY RESPONSIBLE FOR IMPROPER INSTALLATION AND PHYSICAL DAMAGE RESULTING THEREFROM, INCLUDING BUT NOT LIMITED TO, DAMAGE RESULTING FROM LEAKAGE, IMPROPER TORQUING OR SEATING OF A RUPTURE DISC OR FAILURE TO FOLLOW INSTALLATION INSTRUCTIONS WHERE PROVIDED.

RUPTURE DISCS ARE PRECISION SAFETY DEVICES AND MUST BE INSTALLED PROPERLY. RUPTURE DISCS MUST BE INSTALLED BY TRAINED, KNOWLEDGEABLE INSTALLERS AND ONLY WITHIN ENVIRONMENTS SUITABLE AND APPROPRIATE FOR A RUPTURE DISC. CARE MUST BE USED IN A FACILITY'S DESIGN TO PROTECT BOTH THE RUPTURE DISC FROM INADVERTENT DAMAGE WHICH COULD CAUSE ITS PREMATURE RELEASE AND TO PROTECT INDIVIDUALS EXPOSED TO HAZARDS CREATED BY SUCH SUDDEN RELEASE.

PROPER INSTALLATION OF A RUPTURE DISC IS CRITICAL TO PERFORMANCE AND TO SAFETY. FAILURE TO PROVIDE PROPER SEATING OF A RUPTURE DISC MAY AFFECT RUPTURE DISC PERFORMANCE, BURST PRESSURE ACCURACY AND MAY RESULT IN ITS PREMATURE FAILURE.

## I. Safety Precautions Before Installation

1. The knifeblades are very sharp. Care must be taken during handling to prevent serious bodily injury. The knifeblades must be free of corrosion, nicks or bent points to ensure proper performance. If any of these conditions exist, the rating of the rupture disc will increase beyond the original rupture pressure rating.
2. The ZAP rupture disc is a precision instrument and must be handled with extreme care. Rupture discs should be installed only by qualified personnel familiar with rupture discs and proper piping practices.
3. Do not install rupture disc if there is any damage in the dome area. A damaged rupture disc is any rupture disc with visible nicks or dents in the dome.
4. Continental Disc Corporation does not recommend reinstalling a rupture disc that has been removed from the holder as reinstallation may adversely affect the joint sealing capabilities and/or performance of the rupture disc.
5. See rupture disc tag to verify set pressure, operating temperature, and all other operating parameters.

## II. Preparation of Holders for Installation

### New Installation

Clean all foreign material from the rupture disc sealing areas.

### Replacement Installation

1. If the Burst Disc Indicator (B.D.I.®) Alarm System is used, disconnect the alarm strip from the monitor by unplugging the B.D.I. connector from the lead wire connector.
2. On ZAP units with replaceable knifeblade assemblies, remove the knifeblade assembly and spiral wound gasket.
3. Remove the holder from the system and place on a flat surface.
4. Disassemble the holder by loosening the pre-assembly screws on the holder outlet. Lift the holder outlet up and set aside; then remove the burst rupture disc.
5. Clean the rupture disc sealing area of both the holder inlet and outlet. These surfaces must be completely clean and free of all rust, corrosion, and foreign material to ensure a proper seal. Use of solvents, steel wool, or fine emery cloth is permissible. Do not re-machine. Do not use scraper or abrasives.
6. Inspect the rupture disc sealing area for nicks, scratches, or pitting. If any of these conditions are present, consult the factory for repair.
7. **EXAMINE THE KNIFEBLADE CONDITION. BLADE EDGES AND POINTS MUST BE SHARP TO ENSURE PROPER RUPTURE DISC FUNCTION. DO NOT INSTALL RUPTURE DISC IF BLADE EDGES OR POINTS ARE DAMAGED OR CORRODED. IF THE ZAP RUPTURE DISC IS SUPPLIED WITH PERMANENTLY ATTACHED KNIFEBLADES, REPLACEMENT MUST BE PERFORMED AT THE FACTORY. USE ONLY KNIFEBLADE ASSEMBLIES AND GASKETS FURNISHED BY CONTINENTAL DISC CORPORATION.**
8. Remove any adhered gasket material from previous installation.
9. If current pressure conditions differ from that of the initial installation, **ENSURE THAT THE RUPTURE DISC DOES NOT EXCEED MAXIMUM RUPTURE DISC RATING STAMPED ON THE HOLDER NAMEPLATE.** If this condition occurs, consult the factory.

## III. Assembly of the Rupture Disc and Holder (See Figure A)

Component parts of the ZAP Assembly are illustrated in the proper installation sequence.

1. If the B.D.I. Alarm System is to be used, refer to the Universal B.D.I. Assembly Installation Instructions for additional details.

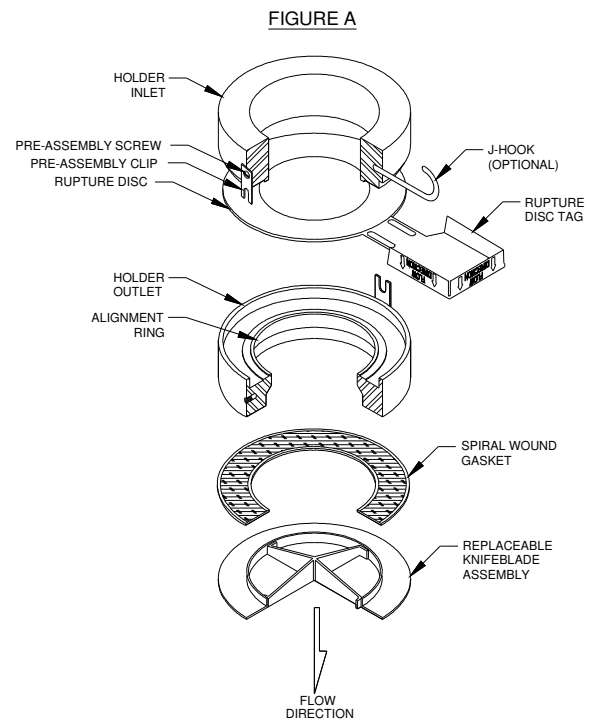

2. Carefully remove and discard any shipping protectors furnished with rupture discs or holder. **DO NOT INSTALL A SHIPPING PROTECTOR IN A HOLDER ASSEMBLY.**
3. Place the holder outlet on a flat surface.
4. Place the ZAP rupture disc in the holder outlet dome side up, and centered on the outlet alignment ring with the rupture disc tag extending through the milled slot in the holder outlet.
5. Align and lower the holder inlet carefully onto the holder outlet. Ensure that the ZAP rupture disc remains properly centered on the alignment ring.
6. Fasten the assembly together by tightening the pre-assembly screws.
7. **AT THIS POINT THE HOLDER ASSEMBLY IS UPSIDE DOWN. INVERT ASSEMBLED RUTPURE DISC AND HOLDER.**
8. If the knifeblades are permanently attached, no further assembly is required. If replaceable knifeblades are used, continue.
9. Place the spiral wound gasket on top of the holder outlet (a spiral wound gasket must be used between the holder outlet and the replaceable knifeblade assembly to allow proper function of the rupture disc).
10. Center the knifeblade assembly on top of the gasket.

#### IV. Installation of the ZAP Assembly Into the System (See Figure B)

1. Before placing the assembly into the system, ensure that the companion flange gasket surfaces are clean and free of all rust, corrosion, and foreign material (spiral wound gaskets are not recommended for use as companion flange gaskets).
2. A J-Hook (optional) may be provided in the holder inlet to ensure correct installation of the assembly relative to flow direction. If the J-Hook is used, the corresponding inlet companion flange must be drilled to accommodate the J-Hook prior to installation of the assembly. Refer to the J-Hook Installation Guide for locating and drilling specifications.
3. Install the ZAP assembly and customer furnished gaskets **WITH ALL FLOW ARROWS POINTING IN THE PROPER FLOW DIRECTION** and the J-Hook (if furnished) inserted into the drilled companion flange.
4. If an outlet protective cover is ordered, install it between the ZAP rupture disc assembly and the gasket of the outlet companion flange.
5. Install lightly oiled, free running studs and nuts to finger tightness. Using a cross torquing pattern (see **Figure C**), torque each nut with a calibrated torque wrench at 20% increments of the recommended torque value (see **Table 1, page 5**). Repeat 20% increments and cross torquing pattern until final torque value is achieved. Recheck all nuts in rotational sequence at final torque value. These values are based using gasket materials having a gasket factor of 2.75, gasket seating stress of 3,700 and stud and nut material per ASME SA193-B7 and SA194-2H respectively, with a stress of up to 25,000 psi. The use of studs and nuts with lower strength may prove unsatisfactory.

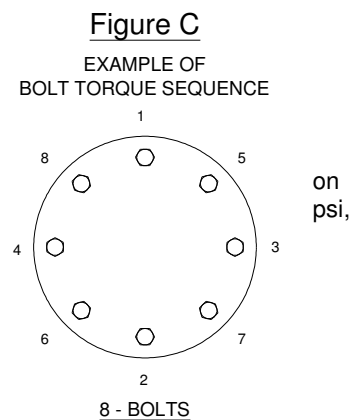
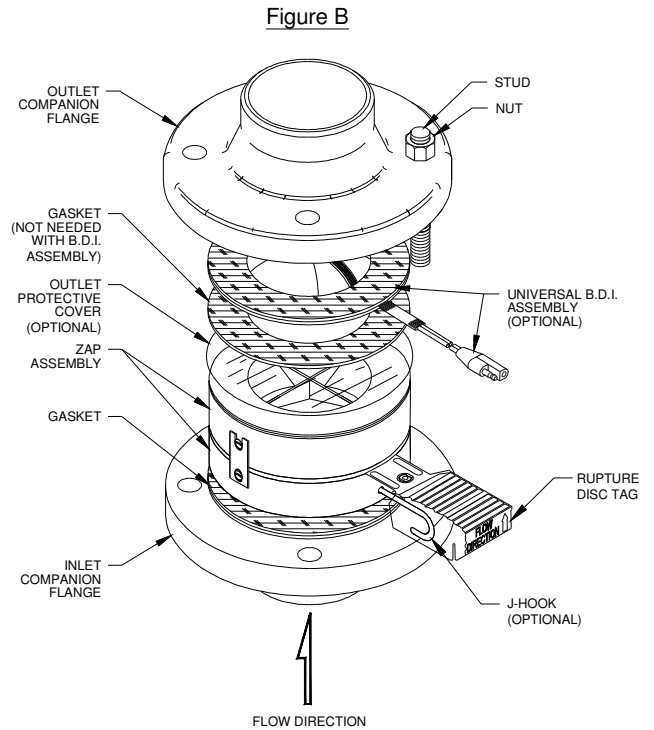

## V. Preventative Maintenance

1. Risk assessment and an annual rupture disc replacement are recommended. Rupture disc service life is determined by system operating conditions. The effects of severe pressure/vacuum cycles, corrosion, temperature variations, or other adverse conditions must be evaluated by the user through actual service experience to determine optimal service life.
2. **IF THE RUPTURE DISC IS NOT REPLACED PERIODICALLY WHEN EXPOSED TO THESE CONDITIONS, PREMATURE FAILURE OF THE RUPTURE DISC MAY OCCUR, THEREBY DISCHARGING THE PROCESS MEDIA.**
3. **INSPECT KNIFEBLADE CONDITION AT EACH RUPTURE DISC CHANGEOUT.** See Section II, Item 7. A minimum of one replaceable knifeblade assembly should be maintained for each ZAP assembly in use. Consult the factory if knifeblade replacement is required on units with welded-in knifeblades.
4. To avoid extended downtime, maintain three spare rupture discs in stock at all times for each holder in use. The number of spares required ultimately will be determined by service conditions.

## VI. Customer Service

If you wish to discuss your application, installation, or maintenance, please contact the Customer Service Department at our headquarters location.

### B.D.I. ALARM SYSTEM OPERATING LIMITS

TEMPERATURE: -40° F to + 400° F  
(-40° C to + 204° C)

MAX CURRENT: 50 Milli Amps  
MAX VOLTAGE: 24 VDC

FULFILLS THE REQUIREMENTS OF DIRECTIVE 94/9/EC (ATEX) FOR: Equipment or protective system intended for use in potentially explosive atmospheres.

Conformity assessment performed by Notified Body no. 0359, Intertek Testing and Certification Limited, Leatherhead, Surrey, UK.

BURST DISC INDICATOR (B.D.I.<sup>®</sup>): Sizes 25mm through 900mm (1 inch through 36 inches)

Marked:  II 1 G Ex ia IIC Tx Ga  
II 1 D Ex ia IIIC Tx Da  
(Tamb = -40° C to +204° C)

EC Type Examination Certificate: ITS13ATEX27734X

THE MAXIMUM INTRINSICALLY SAFE INPUT PARAMETERS ARE AS FOLLOWS:

Ui = 24V dc  
Ii = 50 mA  
Pi = 0.3W

THE EQUIVALENT PARAMETERS ARE:

Ci = 0  
Li = 0

SPECIAL CONDITIONS FOR SAFE USE:

1. The arrangements for connection of the external circuits must comply with the requirements of clause 6.2 of EN 60079-11:2012.
2. The component must be housed in an enclosure which provides a degree of protection of at least IP 20.
3. The final installation shall comply with the 500 volt electrical strength test requirement of clause 6.3.12 of EN 60079-11:2012.
4. The installation shall prevent electrostatic charging of the BDI strip, which is non-conductive and may exceed the surface area limitations of EN 60079-0:2012 clause 7.4.2.

Recommended Torque Values for ZAP  
Rupture Discs Sizes 1" through 8"  
TABLE 1

| SIZE  |    | COMPANION FLANGE RATING |       |       | RECOMMENDED TORQUE VALUE |     | SIZE |     | COMPANION FLANGE RATING |       |       | RECOMMENDED TORQUE VALUE |     |
|-------|----|-------------------------|-------|-------|--------------------------|-----|------|-----|-------------------------|-------|-------|--------------------------|-----|
| IN    | MM | ANSI                    | DIN   | JIS   | FT•LB                    | N•m | IN   | MM  | ANSI                    | DIN   | JIS   | FT•LB                    | N•m |
| 1     | 25 | 150                     | ----  | ----  | 35                       | 47  | 3    | 80  | 300/600                 | ----  | ----  | 120                      | 163 |
| 1     | 25 | ----                    | 10/16 | ----  | 33                       | 45  | 3    | 80  | ----                    | 25/40 | ----  | 101                      | 137 |
| 1     | 25 | ----                    | ----  | 10/20 | 44                       | 60  | 3    | 80  | ----                    | ----  | 20/40 | 126                      | 171 |
| 1     | 25 | 300/600                 | ----  | ----  | 65                       | 88  |      |     |                         |       |       |                          |     |
| 1     | 25 | ----                    | 25/40 | ----  | 49                       | 66  | 4    | 100 | 150                     | ----  | ----  | 65                       | 88  |
| 1     | 25 | ----                    | ----  | 30/40 | 66                       | 89  | 4    | 100 | ----                    | 10/16 | 10    | 66                       | 89  |
|       |    |                         |       |       |                          |     | 4    | 100 | ----                    | ----  | 16/20 | 82                       | 111 |
| 1-1/2 | 40 | 150                     | ----  | ----  | 35                       | 47  | 4    | 100 | 300                     | ----  | ----  | 120                      | 163 |
| 1-1/2 | 40 | ----                    | 10/16 | 10/20 | 44                       | 60  | 4    | 100 | ----                    | 25/40 | ----  | 126                      | 171 |
| 1-1/2 | 40 | 300/600                 | ----  | ----  | 120                      | 163 | 4    | 100 | ----                    | ----  | 30    | 139                      | 188 |
| 1-1/2 | 40 | ----                    | 25/40 | ----  | 101                      | 137 | 4    | 100 | 600                     | ----  | ----  | 130                      | 176 |
| 1-1/2 | 40 | ----                    | ----  | 30/40 | 126                      | 171 | 4    | 100 | ----                    | ----  | 40    | 129                      | 175 |
|       |    |                         |       |       |                          |     |      |     |                         |       |       |                          |     |
| 2     | 50 | 150                     | ----  | ----  | 65                       | 88  | 6    | 150 | 150                     | ----  | ----  | 120                      | 163 |
| 2     | 50 | ----                    | 10/16 | 10    | 66                       | 89  | 6    | 150 | ----                    | 10/16 | 10    | 126                      | 171 |
| 2     | 50 | ----                    | ----  | 16/20 | 33                       | 45  | 6    | 150 | ----                    | ----  | 16/20 | 92                       | 125 |
| 2     | 50 | 300/600                 | ----  | ----  | 65                       | 88  | 6    | 150 | 300                     | ----  | ----  | 120                      | 163 |
| 2     | 50 | ----                    | 25/40 | ----  | 131                      | 178 | 6    | 150 | ----                    | 25/40 | ----  | 227                      | 308 |
| 2     | 50 | ----                    | ----  | 30/40 | 66                       | 89  | 6    | 150 | ----                    | ----  | 30    | 151                      | 205 |
|       |    |                         |       |       |                          |     | 6    | 150 | 600                     | ----  | ----  | 180                      | 244 |
| 2-1/2 | 65 | 150                     | ----  | ----  | 65                       | 88  | 6    | 150 | ----                    | ----  | 40    | 170                      | 230 |
| 2-1/2 | 65 | ----                    | 10/16 | 10    | 33                       | 45  |      |     |                         |       |       |                          |     |
| 2-1/2 | 65 | ----                    | ----  | 16/20 | 66                       | 89  | 8    | 200 | 150                     | ----  | ----  | 130                      | 176 |
| 2-1/2 | 65 | 300/600                 | ----  | ----  | 110                      | 149 | 8    | 200 | ----                    | 10    | ----  | 136                      | 184 |
| 2-1/2 | 65 | ----                    | 25/40 | ----  | 131                      | 178 | 8    | 200 | ----                    | 16    | 10    | 91                       | 123 |
| 2-1/2 | 65 | ----                    | ----  | 30/40 | 66                       | 89  | 8    | 200 | ----                    | ----  | 16/20 | 100                      | 136 |
|       |    |                         |       |       |                          |     | 8    | 200 | 300                     | ----  | ----  | 180                      | 244 |
| 3     | 80 | 150                     | ----  | ----  | 65                       | 88  | 8    | 200 | ----                    | 25    | 30    | 194                      | 263 |
| 3     | 80 | ----                    | 10/16 | 10    | 33                       | 45  | 8    | 200 | ----                    | 40    | ----  | 219                      | 297 |
| 3     | 80 | ----                    | ----  | 16/20 | 41                       | 56  |      |     |                         |       |       |                          |     |

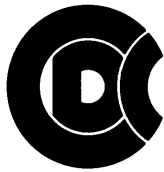

**Continental Disc®  
Corporation**

*Performance Under Pressure®*

**HEADQUARTERS //**  
3160 W. Heartland Drive  
Liberty, MO 64068 USA  
Ph (816) 792-1500  
Fax (816) 792-2277  
sales@contdisc.com  
contdisc.com