



**Continental Disc®
Corporation**

Preparation and Installation of the Special 300# ASME ENVIRO-SEAL I Rupture Disc

WARNING

USER SHOULD READ AND THOROUGHLY UNDERSTAND THESE INSTRUCTIONS BEFORE INSTALLING RUPTURE DISC. THESE INSTRUCTIONS DO NOT PURPORT TO ADDRESS ALL OF THE SAFETY FACTORS ASSOCIATED WITH THE RUPTURE DISC'S USE IN SERVICE. IT IS THE RESPONSIBILITY OF THE USER TO ESTABLISH APPROPRIATE SAFETY, HEALTH, AND TRAINING MEASURES FOR THEIR PERSONNEL INSTALLING, SERVICING, OR WORKING IN AN AREA WHERE RUPTURE DISC ASSEMBLIES ARE IN USE. SERVICE AND/OR MAINTENANCE ON OR AROUND THE RUPTURE DISC DEVICE MUST NOT BE PERFORMED WHILE THE DEVICE IS SUBJECTED TO OPERATING PRESSURES AND/OR TEMPERATURES.

IT IS THE USER'S SOLE RESPONSIBILITY FOR DESIGN AND PLACEMENT OF RUPTURE DISCS WITHIN THEIR FACILITY AND UPON THE EQUIPMENT UPON WHICH THE RUPTURE DISC OF USER'S SELECTION IS TO BE LOCATED. IT IS USER'S SOLE RESPONSIBILITY FOR THE DESIGN OF ADEQUATE VENTING AND INSTALLATION OF ADEQUATE VENT PIPING OR DIRECTIONAL FLOW AFTER RUPTURE OCCURS WITH THE RUPTURE DISC AS INTENDED. WHEN SIZE IS SPECIFIED, CONTINENTAL DISC CORPORATION ASSUMES THAT ADEQUATE PROVISIONS HAVE BEEN MADE BY PURCHASER FOR PROPER VENTING OF A SYSTEM TO RELIEVE THE SPECIFIC PRESSURE. LOCATE RUPTURE DISC WHERE PEOPLE OR PROPERTY WILL NOT BE EXPOSED TO THE SYSTEM DISCHARGE IN CASE OF RUPTURE. VENT TOXIC OR FLAMMABLE FUMES OR LIQUIDS TO A SAFE LOCATION TO PREVENT PERSONAL INJURY OR PROPERTY DAMAGE.

IT IS THE USER'S SOLE RESPONSIBILITY TO SPECIFY THE BURST PRESSURE RATING OF A RUPTURE DISC AT A COINCIDENT TEMPERATURE AT WHICH THE RUPTURE DISC IS TO BE USED. A RUPTURE DISC IS A TEMPERATURE SENSITIVE DEVICE. THE BURST PRESSURE OF THE RUPTURE DISC IS DIRECTLY AFFECTED BY ITS EXPOSURE TO THE COINCIDENT TEMPERATURE. GENERALLY, AS THE TEMPERATURE AT THE RUPTURE DISC INCREASES, THE BURST PRESSURE DECREASES; INVERSELY, AS THE TEMPERATURE AT THE RUPTURE DISC DECREASES, THE BURST PRESSURE MAY INCREASE. FAILURE TO PROPERLY UTILIZE A RUPTURE DISC AT THE SPECIFIED COINCIDENT TEMPERATURE COULD CAUSE PREMATURE FAILURE OR OVERPRESSURIZATION OF A SYSTEM.

THE INSTANTANEOUS RELEASE OF PRESSURE FROM THE RUPTURE DISC CAN CREATE VIOLENT NOISES DUE TO THE DISCHARGE AT SONIC VELOCITY. IT IS THE USER'S SOLE RESPONSIBILITY TO PROTECT AGAINST HEARING DAMAGE TO ANY BYSTANDERS.

RUPTURE DISCS AND TAGS ARE MADE OF METAL FOILS OF VARYING THICKNESS. THE METAL EDGES MAY BE SHARP. PERSONNEL INSTALLING OR EXAMINING THE RUPTURE DISCS SHOULD PROTECT AGAINST CUTS OR INJURY WHEN HANDLING THE RUPTURE DISC. DO NOT LIFT A RUPTURE DISC BY ITS ATTACHED TAG.

PARTICLES MAY BE DISCHARGED WHEN THE RUPTURE DISC RUPTURES. THESE PARTICLES MAY BE PART OF THE RUPTURE DISC ITSELF, OR OTHER ENVIRONMENTAL MATTER IN THE SYSTEM. IT IS THE USER'S SOLE RESPONSIBILITY TO ASSURE THAT THESE PARTICLES ARE DIRECTED TO A SAFE AREA TO PREVENT PERSONAL INJURY OR PROPERTY DAMAGE.

THERE IS NO GUARANTEE OF RUPTURE DISC LIFE. SUCH LIFE SPAN IS AFFECTED BY CORROSION, CREEP AND FATIGUE, AND PHYSICAL DAMAGE. THESE CONDITIONS WILL DERATE THE RUPTURE DISC TO A LOWER SET PRESSURE. THE CUSTOMER AND/OR USER SHOULD BE PREPARED TO HANDLE PREMATURE FAILURE OF THE RUPTURE DISC. THE MEDIA OR OTHER ENVIRONMENTAL CONDITIONS SHOULD NOT ALLOW ANY BUILDUP OR SOLIDIFICATION OF MEDIA TO OCCUR ON A RUPTURE DISC. THIS MAY INCREASE THE PRESSURE SETTING OF THE RUPTURE DISC.

CUSTOMER AND/OR ITS INSTALLER SHALL BE SOLELY RESPONSIBLE FOR THE PROPER INSTALLATION OF SELLER'S HOLDERS AND RUPTURE DISCS INTO A SYSTEM. CUSTOMER AND/OR ITS INSTALLER SHALL BE SOLELY RESPONSIBLE FOR IMPROPER INSTALLATION AND PHYSICAL DAMAGE RESULTING THEREFROM, INCLUDING BUT NOT LIMITED TO, DAMAGE RESULTING FROM LEAKAGE, IMPROPER TORQUING OR SEATING OF A RUPTURE DISC OR FAILURE TO FOLLOW INSTALLATION INSTRUCTIONS WHERE PROVIDED.

RUPTURE DISCS ARE PRECISION SAFETY DEVICES AND MUST BE INSTALLED PROPERLY. RUPTURE DISCS MUST BE INSTALLED BY TRAINED, KNOWLEDGEABLE INSTALLERS AND ONLY WITHIN ENVIRONMENTS SUITABLE AND APPROPRIATE FOR A RUPTURE DISC. CARE MUST BE USED IN A FACILITY'S DESIGN TO PROTECT BOTH THE RUPTURE DISC FROM INADVERTENT DAMAGE WHICH COULD CAUSE ITS PREMATURE RELEASE AND TO PROTECT INDIVIDUALS EXPOSED TO HAZARDS CREATED BY SUCH SUDDEN RELEASE.

PROPER INSTALLATION OF A RUPTURE DISC IS CRITICAL TO PERFORMANCE AND TO SAFETY. FAILURE TO PROVIDE PROPER SEATING OF A RUPTURE DISC MAY AFFECT RUPTURE DISC PERFORMANCE, BURST PRESSURE ACCURACY AND MAY RESULT IN ITS PREMATURE FAILURE.

I. Safety Precautions Before Installation

1. The 300# ASME ENVIRO-SEAL I rupture disc is a precision instrument and must be handled with extreme care. Rupture discs should be installed only by qualified personnel familiar with rupture discs and proper piping practices.
2. Do not install rupture disc if there is any damage evident. A damaged rupture disc is any rupture disc with visible nicks or dents.
3. Continental Disc Corporation does not recommend reinstalling a rupture disc that has been removed from the holder as reinstallation may adversely affect the joint sealing capabilities and/or performance of the rupture disc.
4. See rupture disc tag to verify set pressure, operating temperature, and all other operating parameters.

II. Preparation of Companion Flanges for Installation

New Installation

Clean all foreign material from the rupture disc sealing area of the holder inlet, and outlet companion flanges.

Replacement Installation

1. If the Burst Disc Indicator (B.D.I.®) Alarm System is used, disconnect the alarm strip from the monitor by unplugging the B.D.I. connector from the lead wire connector.
2. Remove companion flange studs and nuts and discard burst rupture disc.
3. Remove any adhered gasket material from previous installation.
4. Clean the rupture disc sealing area of both the inlet and outlet companion flanges. These surfaces must be completely clean and free of all rust, corrosion, and foreign material to ensure a proper seal. Use of solvents, steel wool, or fine emery cloth is permissible. Do not re-machine. Do not use scraper or abrasives.

III. Installation of the Rupture Disc into the System (See Figure A)

1. Before placing the rupture disc into the system, ensure that the companion flange gasket surfaces are clean and free of all rust, corrosion, and foreign material.
2. If the B.D.I. Alarm System is used, visually inspect the adhesion of the strip to the seal and the electrical circuit. If the strip has become detached or the circuit has been broken, **DO NOT INSTALL THE RUPTURE DISC**. Ensure that the B.D.I. strip extends straight and flat.
3. Place the rupture disc on the inlet companion flange centered inside the bolt holes, **WITH FLOW ARROWS ON THE RUPTURE DISC TAG POINTING IN THE PROPER FLOW DIRECTION**.
4. Lower the outlet companion flange carefully onto the rupture disc, using care to keep the rupture disc properly aligned.

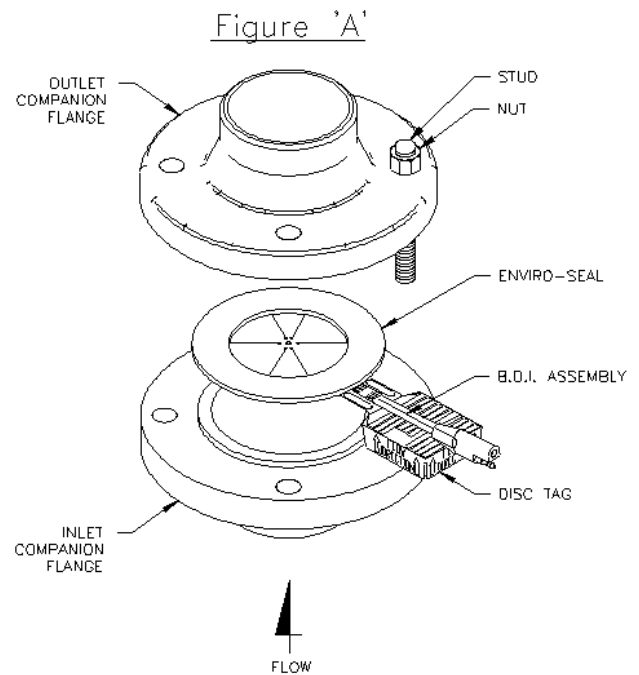

- NOTE: If the B.D.I. Alarm System is used, one stud approximately 2" longer than the others is needed near where the B.D.I. strip exits. Install lightly oiled free running studs and nuts to finger tightness. Using a cross torquing pattern (see **Figure B**), torque each nut with a calibrated torque wrench at 20% increments of recommended torque value (see chart on next page). Repeat 20% increments and cross torquing pattern until final torque value is achieved. Recheck all nuts in rotational sequence at final torque value.
- Use recommended torque values listed below for bolting. These torque values are based on using gasket materials having a gasket factor of 2.75, gasket seating stress of 3,700 psi, and stud and nut material per ASME SA193-B7 and SA194-2H respectively, with a stress of up to 25,000 psi. The use of studs and nuts with lower strength may prove unsatisfactory.
- If the B.D.I. Alarm System is used, installation of the strain relief device is necessary (See **Figure C**). Slip the strain relief device over the longer stud and secure with a nut. Allowing sufficient slack for easy connection to the B.D.I. connector, secure the lead wire to the strain relief device by fastening the twist lock. Plug the B.D.I. connector into the lead wire connector using a slight twisting action.

SIZE	TORQUE	SIZE	TORQUE
1"	65 Ft•Lbs./ (88 N•m)	6"	120 Ft•Lbs./ (163 N•m)
1-1/2"	120 Ft•Lbs./ (163 N•m)	8"	180 Ft•Lbs./ (44 N•m)
2"	65 Ft•Lbs./ (88 N•m)	10"	275 Ft•Lbs./ (373 N•m)
3"	120 Ft•Lbs./ (163 N•m)	12"	375 Ft•Lbs./ (508 N•m)
4"	120 Ft•Lbs./ (163 N•m)		

Figure 'B'
EXAMPLE OF
BOLT TORQUE SEQUENCE

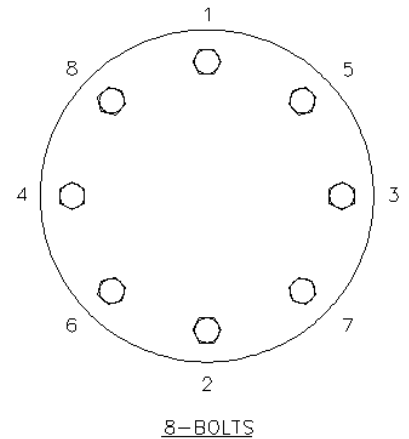
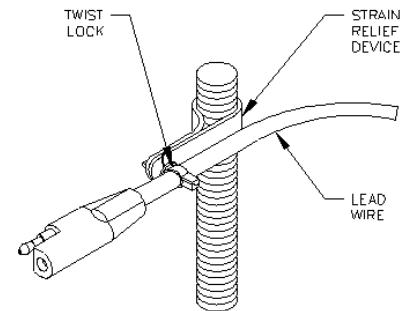

Figure 'C'



IV. Preventative Maintenance

- Risk assessment and an annual rupture disc replacement are recommended. Rupture disc service life is determined by system operating conditions. The effects of severe pressure/vacuum cycles, corrosion, temperature variations, or other adverse conditions must be evaluated by the user through actual service experience to determine optimal service life.
- IF THE RUPTURE DISC IS NOT REPLACED PERIODICALLY WHEN EXPOSED TO THESE CONDITIONS, PREMATURE FAILURE OF THE RUPTURE DISC MAY OCCUR, THEREBY DISCHARGING THE PROCESS MEDIA.**
- To avoid extended downtime, maintain three spare rupture discs in stock at all times for each holder in use. The number of spares required ultimately will be determined by service conditions.

V. Customer Service

If you wish to discuss your application, installation, or maintenance, please contact the Customer Service Department at our headquarters location.

B.D.I. ALARM SYSTEM OPERATING LIMITS

TEMPERATURE: -40° F to + 400° F
 (-40° C to + 204° C)

MAX CURRENT: 50 Milli Amps
MAX VOLTAGE: 24 VDC

FULFILLS THE REQUIREMENTS OF DIRECTIVE 2014/34/EU (ATEX) FOR: Equipment or protective system intended for use in potentially explosive atmospheres.

Conformity assessment performed by Notified Body no. 0359, Intertek Testing and Certification Limited, Leatherhead, Surrey, UK.

BURST DISC INDICATOR (B.D.I.[®]): Sizes 25mm through 900mm (1 inch through 36 inches)

Marked:  II 1 G Ex ia IIC Tx Ga
II 1 D Ex ia IIIC Tx Da
I M1 Ex ia I Ma
(Tamb = -40°C ≤ Ta ≤ +204°C)

EC Type Examination Certificate: ITS13ATEX27734X

THE MAXIMUM INTRINSICALLY SAFE INPUT PARAMETERS ARE AS FOLLOWS:

Ui = 24V dc
Ii = 50 mA
Pi = 0.3W

THE EQUIVALENT PARAMETERS ARE:

Ci = 0
Li = 0

SPECIAL CONDITIONS FOR SAFE USE:

1. Temperature Class of the BDI sensor is marked as Tx, since the surface temperature is controlled by the process temperature being monitored. The sensor itself exhibits negligible temperature rise.
2. When located in an area requiring EPL Ga / Category 1G (e.g. Zone 0) hazardous area, the user shall ensure that electrostatic charging of the non-metallic parts cannot occur.
3. When provided with terminations by means of flying leads, these shall be terminated in an appropriately protected terminal box.
4. When installed, the BDI strip shall be provided with an IP rating of IP20 as a minimum.
5. For Group I applications, the BDI strip and terminations shall be protected to IP54 or better.



**Continental Disc®
Corporation**

Performance Under Pressure®

HEADQUARTERS //
3160 W. Heartland Drive
Liberty, MO 64068 USA
Ph (816) 792-1500
Fax (816) 792-2277
sales@contdisc.com
contdisc.com