

**Continental Disc®
Corporation**

Performance Under Pressure®

SANITRX® RUPTURE DISC

The SANITRX* Rupture Disc is a **semicircular-scored reverse acting rupture disc** designed to provide instantaneous overpressure protection in sanitary environments.

Engineered exclusively for applications concerned with product purity and trouble-free equipment sterilization, the SANITRX Rupture Disc provides overpressure protection for sanitary systems, equipment, and vessels. This solid metal rupture disc is ideal for primary and/or secondary system relief protection and isolating a system or safety relief valve from leakage or permeation.

The SANITRX Rupture Disc is manufactured under an ISO 9001-2000 Certified Quality Assurance System at our state-of-the-art production facility in Liberty, Missouri.

SANITRX Rupture Disc features include:

- **Operation to 90%** of rated burst pressure
- **Zero** manufacturing range as standard
- **Solid metal** construction
- **Handling ring** to reduce torque sensitivity
- **Non-fragmenting design**
- Manufactured to provide a **safety ratio of 1.5 or less**, so if damaged it will relieve at or less than 1.5 times the rated burst pressure of the rupture disc.
- Capable of operating in **gas** or **vapor** service. Consult the factory regarding liquid service application.
- Inherent with most reverse acting types of rupture discs on the market, the SANITRX Rupture Disc will **operate in pressure-to-vacuum cycling** applications without an additional vacuum support component, compared to tension type rupture discs.
- **F.D.A.-grade envelope gasket** provides a perfect fit and seal between new SANITRX ferrules or existing sanitary tube O.D. connections.
- **Individually packaged** in damage resistant containers. See photo page 3.
- **Lower pressures** available in the SANITRX LP™ design. See page 4.

Unique Design

The SANITRX Rupture Disc is produced using Continental's manufacturing methods, combined with our **Non-symmetrical Failure Initiating Indents, Precision Semicircular Scoring, and Arcuate Projection**.

Non-symmetrical Failure Initiating Indents provide a highly accurate method:

- to precisely control disc buckling at a predetermined pressure
- to initiate failure of the rupture disc dome to assure thicker material will properly collapse for a full opening along the score line
- to weaken thicker materials to achieve low reversal pressures. The use of thicker materials provides a disc which is sturdier and less susceptible to corrosion.

Precision Semicircular Scoring

outside of the rupture disc dome helps assure the rupture disc dome will not fragment. The Failure Initiating Indents cause stress on this score line to provide a full relief opening pattern.

An **Arcuate Projection** is attached to the handling ring. When reversal occurs, the rupture disc dome curves around the arcuate to help eliminate fragmentation and provide an unrestricted flow.

Available Sizes

The SANITRX Rupture Disc is available in 1-1/2" through 4" sizes (40 - 100 mm). Rupture disc size dimensions match size classifications of standard sanitary fittings so that a 2" rupture disc fits with standard 2" tube O.D. fittings.

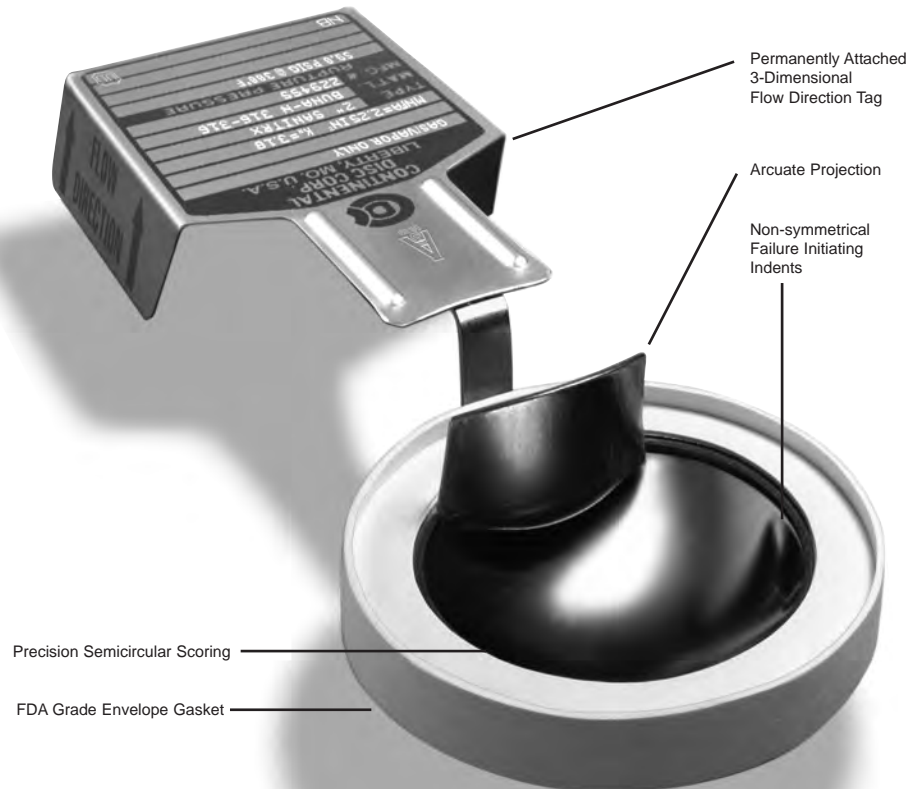

Materials

The SANITRX Rupture Disc is suitable for use in corrosive processes and sterilization procedures found in sanitary environments.

Standard materials available include Nickel, Monel[®]*, 316SS, Inconel[®]** Hastelloy C[®]**, and Tantalum.

Manufacturing Range

The manufacturing range is the *allowable pressure range, based on the customer's specified burst pressure, within which a rupture disc is rated.*

As a standard, SANITRX and SANITRX LP rupture discs are designed with a zero manufacturing range. For applications with operating conditions not requiring a zero range, other ranges are available at reduced pricing. Available ranges include: -2.5 psig or -5 psig for burst pressure ratings below 50 psig and -5% or -10% for rated burst pressures 50 psig and above.

Burst Tolerance

The burst tolerance is the allowable variation in burst pressure from the rated (marked) burst pressure. SANITRX and SANITRX LP rupture discs are manufactured with a burst tolerance of ± 2 psig for pressures up to and including 40 psig, and $\pm 5\%$ for pressures above 40 psig. A minimum of two rupture discs

per lot are burst to determine conformance with the specified burst pressure. The rated burst pressure, marked on the attached flow tag, is established as follows:

- **For zero manufacturing ranges,** the rated burst pressure marked on the tag will be the requested burst pressure.
- **For -5%, -10%, -2.5 psig, and -5 psig manufacturing ranges,** the marked burst pressure is the average of the rupture disc burst test results.

The rupture disc burst tolerance applies to the rated (marked) burst pressure.

90% Recommended Operating Pressure

For rated burst pressures below 40 psig, the recommended operating pressure is 90% of the value of the rated (marked) burst pressure minus the burst tolerance (i.e., [marked rating minus the 2 psig burst tolerance] x .90).

For rated burst pressures 40 psig and above, the recommended operating pressure is 90% of the rated (marked) burst pressure indicated on the tag.



Rupture Disc Tagging

Continental Disc Corporation, **the leader in industry innovation**, introduced the **permanently attached 3-dimensional flow direction tag** to provide a convenient indicator of proper rupture disc orientation and alignment.

Every SANITRX and SANITRX LP rupture disc is furnished with a 3-D flow tag that is pinstamped with the manufacturing number, burst rating, temperature rating and any customer supplied identification information. The SANITRX Rupture Disc tag design is engineered to fit within tube O.D. connections secured by sanitary type clamps.



* Inconel and Monel are registered trademarks of the Inco family of companies.
 ** Hastelloy C is a registered trademark of Haynes International.

SPECIAL APPLICATIONS

SANITRX LP™ Rupture Disc

For applications that require lower pressures with reduced flow resistance, Continental Disc offers the SANITRX LP Rupture Disc. This new rupture disc was designed specifically to provide the same features as the original SANITRX Rupture Disc, but with the added benefit of lower available burst pressures.

Plus, through the benefit of using our on-site ASME Accepted Flow Test Laboratory, the SANITRX LP Rupture Disc has been designed to have one of the lowest K_R flow resistance factors

available in a rupture disc of any design — from any manufacturer. See CERTIFLOW® bulletin #1-1112 for more information.

The SANITRX LP Rupture Disc is available in the materials shown in Table I, in standard sizes of 1" through 3" (25 - 80 mm). Rupture disc size dimensions match size classifications of standard sanitary fittings so that a 2" rupture disc fits within standard 2" tube O.D. fittings. Other sizes are available upon request. Consult the factory or your local representative for more information.

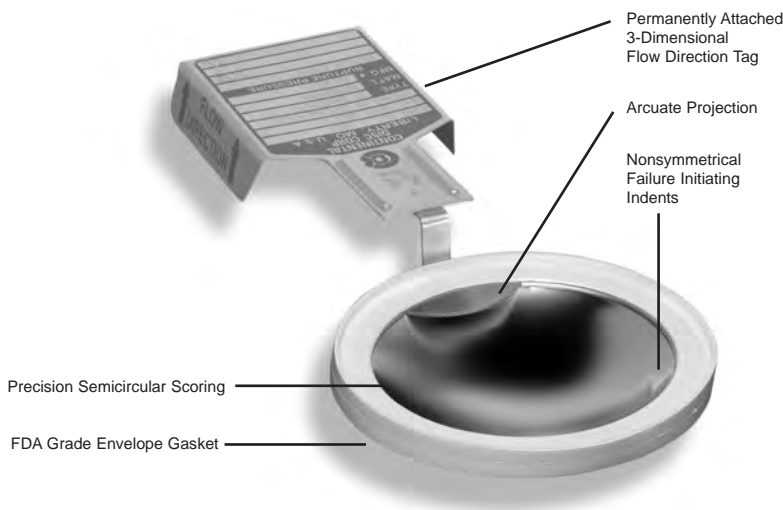

SANITRX NA™ Rupture Disc



Continental Disc also manufactures rupture discs specifically to fit within the sanitary clamping design of the NovAseptic NA-connect® holder. This flush-mount holder is becoming increasingly popular in sanitary processing industries because it allows installation of the rupture disc directly against the wall of the vessel, to allow for easy cleaning and sterilization.

The SANITRX NA™ Rupture Disc is available in pressure ranges to match the original SANITRX design, as well as for lower pressure applications (SANITRX LPNA™). It is available in all sizes and materials as shown in Table I. Consult the factory for more information about the SANITRX NA Rupture Disc, and about available gasket materials.

Table I - SANITRX and SANITRX LP Minimum - Maximum Burst Pressures at 72° F (22° C)

White bar indicates “psig”. Gray bar indicates “barg”. Values also apply to SANITRX NA and SANITRX LPNA.

Nominal Size	SANITRX						Nominal Size	SANITRX LP			
	Rupture Disc Materials							Rupture Disc Materials			
	316SS / Inconel		Tantalum Nickel / Monel		Hastelloy C			316SS / Inconel		Nickel / Monel	
	Min	Max	Min	Max	Min	Max		Min	Max	Min	Max
–	–	–	–	–	–	–	1 in	25	200	25	150
–	–	–	–	–	–	–	25 mm	1,73	13,7	1,73	10,3
1-1/2 in	22	500	20	500	40	500	1-1/2 in	10	60	10	60
40 mm	1,52	34,5	1,38	34,5	2,76	34,5	40 mm	0,690	4,13	0,690	4,13
2 in	18	450	16	450	30	450	2 in	10	60	10	60
50 mm	1,24	31,0	1,10	31,0	2,07	31,0	50 mm	0,690	4,13	0,690	4,13
3 in	16	175	15	175	26	175	3 in	10	40	10	30
80 mm	1,10	12,1	1,03	12,1	1,79	12,1	80 mm	0,690	2,75	0,690	2,06
4 in	14	100	14	100	24	100	–	–	–	–	–
100 mm	0,965	6,89	0,965	6,89	1,65	6,89	–	–	–	–	–

Table I Note: Minimum pressures are based upon the minimum of the manufacturing range @ 72°F (22°C).

Code Compliance

When specified, the SANITRX and SANITRX LP rupture discs will be provided in accordance with Section VIII of the ASME Code. For these applications, Continental Disc will manufacture, temperature test, and tag rupture discs to comply with the ASME Code.

Continental Disc Corporation has been accredited and is authorized by the ASME Code to utilize the  Code Symbol Stamp for product built in

accordance with the requirements of the ASME Boiler and Pressure Vessel Code, Section VIII, Division 1.

The flow performance of the SANITRX and SANITRX LP rupture discs was certified by The National Board of Boiler and Pressure Vessel Inspectors. These certified flow resistance (K_R) and minimum net flow area values are available from Continental Disc Corporation or The National Board of Boiler and Pressure Vessel Inspectors. See CERTIFLOW bulletin #1-1112 for more information.

Continental Disc Corporation maintains an ASME Accepted Flow Test Laboratory. This facility enables flow testing for rupture discs, pressure relief valves, and disc/valve combinations. See Flow Test Laboratory bulletin #1-1106 for flow testing information.

 marked SANITRX and SANITRX LP rupture discs, in accordance with Pressure Equipment Directive 97/23EC, are available when specified.

Each lot of rupture discs manufactured by Continental Disc Corporation is furnished with a BURST CERTIFICATE, providing burst test information.

Clamps

The SANITRX and SANITRX LP rupture discs are designed to install directly between sanitary tube O.D. connections secured with a sanitary clamping device like Continental Disc Corporation's single hinge or multiple-bolt sanitary clamps, or model #13MHM Tri-Clover[®], Cherry-Burrell sanitary type clamps, or equivalent.

Sanitary type clamps are available for new SANITRX and SANITRX LP ferrule installations or existing tube O.D. fittings. See photo page 3.

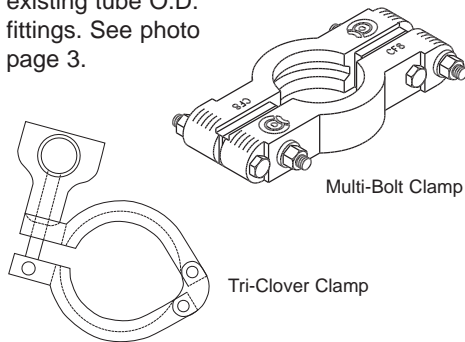

Gaskets

The SANITRX and SANITRX LP rupture discs are furnished with an envelope gasket which encapsulates the rupture disc flange for sealing. The gaskets are available in the materials shown in Table II, which meet F.D.A. and 3-A standards.

Table II shows the recommended gasket operating temperatures. Consult the factory for specific application information.

Table II - Gasket Temperatures

Material	Service Temperatures			
	Minimum		Maximum	
	deg F	deg C	deg F	deg C
Silicone	-80	-62	450	232
Platinum Cured Silicone	-80	-62	350	177
White Viton [®] **	-20	-29	400	204
Black Viton	-20	-29	400	204
White Buna-n	-40	-40	225	107
Black Buna-n	-40	-40	225	107
White EPDM	-55	-48	275	135
Black EPDM	-55	-48	300	149
PTFE Teflon [®] ** (Note 1)	-40	-40	450	232
Teflon Steel	-20	-29	450	232

Note 1: PTFE gasket in 4" size (100 mm) for use with Multi-Bolt Clamp or NA-Connect applications only.

B.D.I.[®] (Burst Disc Indicator) Alarm System

The B.D.I. Alarm System monitors the status of a rupture disc and immediately signals when an overpressure condition occurs.

Directly activated during system relief through the rupture disc, the B.D.I. Alarm System protects valuable products and equipment by instantly warning process employees of potential

loss or contamination. The integrally designed B.D.I. Alarm Strip is available on all SANITRX and SANITRX LP rupture discs. See Rupture Discs with B.D.I. Alarm System bulletin #5-7701-5 for more information.

The B.D.I. Alarm Strip is certified as a component for use in potentially explosive atmospheres in accordance with European Directive 94/9/EC ATEX.

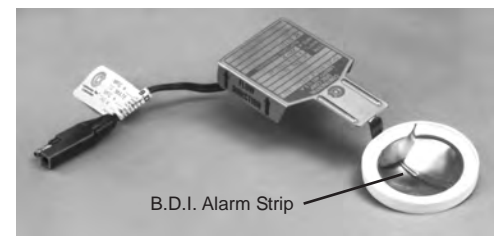

* Tri-Clover is a registered trademark of Tri-Clover Inc.

** Teflon and Viton are registered trademarks of E.I. du Pont de Nemours and Company used under license.

ACCESSORIES

Table III - Spool Piece

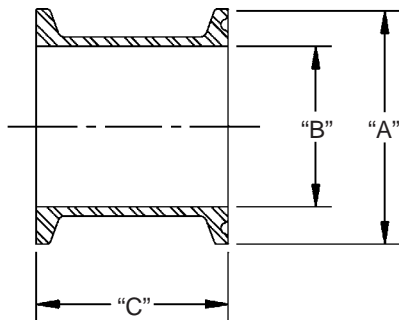

Nominal Size	Dimensions			Weight
	"A"	"B"	"C"	
1 in.	1.98	0.85	1.63	-
25 mm	50,3	21,6	41,4	-
1-1/2 in.	1.98	1.36	1.63	0.27 lb
40 mm	50,3	34,5	41,4	0,12 kg
2 in.	2.52	1.86	1.63	0.37 lb
50 mm	64,0	47,2	41,4	0,17 kg
3 in.	3.58	2.86	2.25	0.59 lb
80 mm	90,9	72,6	57,2	0,27 kg
4 in.	4.68	3.81	2.25	1.00 lbs
100 mm	118,9	96,8	57,2	0,45 kg

Table IV - Tank Weld Ferrule

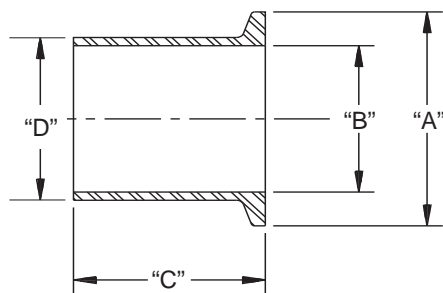

Nominal Size	Dimensions				Weight
	"A"	"B"	"C"	"D"	
1 in.	1.98	0.85	1.63	1.15	-
25 mm	50,3	21,6	41,4	29,2	-
1-1/2 in.	1.98	1.36	1.63	1.68	0.22 lb
40 mm	50,3	34,5	41,4	42,7	0,10 kg
2 in.	2.52	1.86	1.75	2.19	0.31 lb
50 mm	64,0	47,2	44,5	55,6	0,14 kg
3 in.	3.58	2.86	1.81	3.22	0.51 lb
80 mm	90,9	72,6	46,0	81,8	0,23 kg
4 in.	4.68	3.81	2.13	4.26	0.97 lb
100 mm	118,9	96,8	54,1	108,2	0,44 kg

Table V - Butt Weld Ferrule

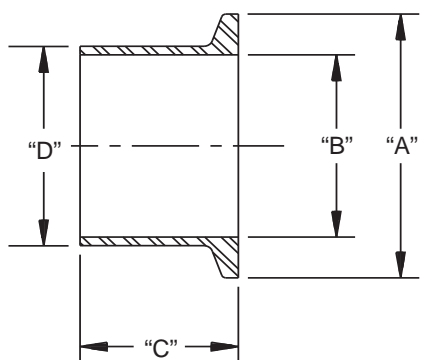

Nominal Size	Dimensions				Weight
	"A"	"B"	"C"	"D"	
1 in.	1.98	0.87	1.13	1.00	-
25 mm	50,3	22,1	28,7	25,4	-
1-1/2 in.	1.98	1.37	1.13	1.50	0.15 lb
40 mm	50,3	34,8	28,7	38,1	0,07 kg
2 in.	2.52	1.87	1.13	2.00	0.21 lb
50 mm	64,0	47,5	28,7	50,8	0,10 kg
3 in.	3.58	2.87	1.13	3.00	0.34 lb
80 mm	90,9	72,9	28,7	76,2	0,15 kg
4 in.	4.68	3.83	1.13	4.00	0.56 lb
100 mm	118,9	97,3	28,7	101,6	0,25 kg

Table VI - Concentric Reducer

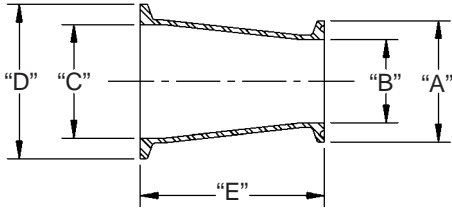

Nominal Size	Dimensions					Weight
	"A"	"B"	"C"	"D"	"E"	
1-1/2 in. x 1 in.	1.98	.86	1.36	1.98	3.00	0.27 lb
40 mm x 25 mm	50,3	21,8	34,5	50,3	76,2	0,12 kg
2 in. x 1-1/2 in.	1.98	1.36	1.86	2.52	3.00	0.48 lb
50 mm x 40 mm	50,3	34,5	47,2	64,0	76,2	0,22 kg
3 in. x 2 in.	2.52	1.86	2.86	3.58	5.00	1.05 lb
80 mm x 50 mm	64,0	47,2	72,6	90,9	127,0	0,48 kg
4 in. x 3 in.	3.58	2.86	3.81	4.68	5.13	1.74 lb
100 mm x 80 mm	90,9	72,6	96,8	118,9	130,3	0,79 kg

NOTE: On concentric reducers, the SANITRX Rupture Disc is always installed on the larger end to prevent flow restrictions.

Table VII - Spool Piece with Gauge Tap

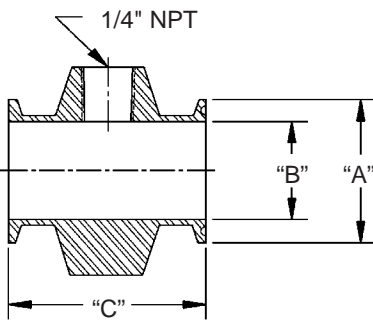

Nominal Size	Dimensions		
	"A"	"B"	"C"
1 in.	1.98	0.86	3.00
25 mm	50,3	21,8	76,2
1-1/2 in.	1.98	1.36	3.00
40 mm	50,3	34,5	76,2
2 in.	2.51	1.86	3.00
50 mm	63,8	47,2	76,2
3 in.	3.58	2.86	3.00
80 mm	90,9	72,6	76,2
4 in.	4.68	3.81	3.00
100 mm	119	96,8	76,2

ORDERING

To assure selection of the correct rupture disc for your application, please determine:

Rupture Disc Specifications

- (1) Quantity
- (2) Size
- (3) Rupture disc material
- (4) Gasket material
- (5) Teflon coating (either or both sides)
- (6) Manufacturing range:
Zero;
-5% or -10% (50 psig or above);
-2.5 psig or -5 psig (below 50 psig)
- (7) Specified pressure/specified temperature
- (8) Accessories... ferrules, clamps, B.D.I. Alarm System

Operating Specifications

- (1) Maximum allowable working pressure (M.A.W.P.)
- (2) Operating pressure
- (3) Operating temperature
- (4) Vacuum/backpressure
- (5) Cycle conditions
- (6) Flow rate required
- (7) Media
- (8) Molecular weight/specific gravity
- (9) For use under a relief valve
- (10) Previous manufacturing number (if known)

Code Compliance

- (1) Codes: ASME, 3A, ISO, DIN, JIS, BSI, EN or others
- (2) Special cleaning
- (3) Special tagging
- (4) Temperature testing
- (5) Material test reports
- (6) Other

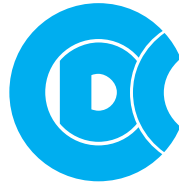

**Continental Disc[®]
Corporation**

Performance Under Pressure[®]



ASME Code Symbol Stamp
Available When Specified

China Manufacture License
Available When Specified



Pressure Equipment Directive
Available When Specified



3A Sanitary Standards Stamp
Available When Specified

Continental Disc Corporation has representatives located throughout the world.
Contact the Continental Disc Corporation office nearest you for the authorized representative in your area.

CORPORATE HEADQUARTERS

Continental Disc Corporation
3160 W. Heartland Drive
Liberty, Missouri 64068-3385 USA

Phone: (816) 792-1500
FAX: (816) 792-2277 / 5447
E-mail: pressure@contdisc.com
Website: www.contdisc.com

THE NETHERLANDS

Continental Disc Corporation
Energieweg 20
2382 NJ Zoeterwoude-Rijndijk
The Netherlands

Phone: + (31) 71-5412221
FAX: + (31) 71-5414361
E-mail: cdcnl@contdisc.com

CHINA

Continental Disc Corporation
Room 910, Tower B, COFCO Plaza
No. 8 JianGuoMenNei Avenue
Beijing (100005), P.R. China

Phone: + (86) 10-6522-4885
Fax: + (86) 10-6522-2885
Mobile: + (86) 137-0103-8871
E-mail: cdcchina@contdisc.com

INDIA

Groth Continental Mfg. Pvt. Ltd.
Survey No. 423/P, Mahagujarat Industrial
Estate, Moraiya, Sarkhej-Bavlva Road,
Ahmedabad 382213, INDIA

E-mail: gcmpl@contdisc.com