



**Continental Disc®
Corporation**

Preparation and Installation of the ENVIRO-SEAL I Rupture Disc

WARNING

USER SHOULD READ AND THOROUGHLY UNDERSTAND THESE INSTRUCTIONS BEFORE INSTALLING RUPTURE DISC. THESE INSTRUCTIONS DO NOT PURPORT TO ADDRESS ALL OF THE SAFETY FACTORS ASSOCIATED WITH THE RUPTURE DISC'S USE IN SERVICE. IT IS THE RESPONSIBILITY OF THE USER TO ESTABLISH APPROPRIATE SAFETY, HEALTH, AND TRAINING MEASURES FOR THEIR PERSONNEL INSTALLING, SERVICING, OR WORKING IN AN AREA WHERE RUPTURE DISC ASSEMBLIES ARE IN USE. SERVICE AND/OR MAINTENANCE ON OR AROUND THE RUPTURE DISC DEVICE MUST NOT BE PERFORMED WHILE THE DEVICE IS SUBJECTED TO OPERATING PRESSURES AND/OR TEMPERATURES.

IT IS THE USER'S SOLE RESPONSIBILITY FOR DESIGN AND PLACEMENT OF RUPTURE DISCS WITHIN THEIR FACILITY AND UPON THE EQUIPMENT UPON WHICH THE RUPTURE DISC OF USER'S SELECTION IS TO BE LOCATED. IT IS USER'S SOLE RESPONSIBILITY FOR THE DESIGN OF ADEQUATE VENTING AND INSTALLATION OF ADEQUATE VENT PIPING OR DIRECTIONAL FLOW AFTER RUPTURE OCCURS WITH THE RUPTURE DISC AS INTENDED. WHEN SIZE IS SPECIFIED, CONTINENTAL DISC CORPORATION ASSUMES THAT ADEQUATE PROVISIONS HAVE BEEN MADE BY PURCHASER FOR PROPER VENTING OF A SYSTEM TO RELIEVE THE SPECIFIC PRESSURE. LOCATE RUPTURE DISC WHERE PEOPLE OR PROPERTY WILL NOT BE EXPOSED TO THE SYSTEM DISCHARGE IN CASE OF RUPTURE. VENT TOXIC OR FLAMMABLE FUMES OR LIQUIDS TO A SAFE LOCATION TO PREVENT PERSONAL INJURY OR PROPERTY DAMAGE.

IT IS THE USER'S SOLE RESPONSIBILITY TO SPECIFY THE BURST PRESSURE RATING OF A RUPTURE DISC AT A COINCIDENT TEMPERATURE AT WHICH THE RUPTURE DISC IS TO BE USED. A RUPTURE DISC IS A TEMPERATURE SENSITIVE DEVICE. THE BURST PRESSURE OF THE RUPTURE DISC IS DIRECTLY AFFECTED BY ITS EXPOSURE TO THE COINCIDENT TEMPERATURE. GENERALLY, AS THE TEMPERATURE AT THE RUPTURE DISC INCREASES, THE BURST PRESSURE DECREASES; INVERSELY, AS THE TEMPERATURE AT THE RUPTURE DISC DECREASES, THE BURST PRESSURE MAY INCREASE. FAILURE TO PROPERLY UTILIZE A RUPTURE DISC AT THE SPECIFIED COINCIDENT TEMPERATURE COULD CAUSE PREMATURE FAILURE OR OVERPRESSURIZATION OF A SYSTEM.

THE INSTANTANEOUS RELEASE OF PRESSURE FROM THE RUPTURE DISC CAN CREATE VIOLENT NOISES DUE TO THE DISCHARGE AT SONIC VELOCITY. IT IS THE USER'S SOLE RESPONSIBILITY TO PROTECT AGAINST HEARING DAMAGE TO ANY BYSTANDERS.

RUPTURE DISCS AND TAGS ARE MADE OF METAL FOILS OF VARYING THICKNESS. THE METAL EDGES MAY BE SHARP. PERSONNEL INSTALLING OR EXAMINING THE RUPTURE DISCS SHOULD PROTECT AGAINST CUTS OR INJURY WHEN HANDLING THE RUPTURE DISC. DO NOT LIFT A RUPTURE DISC BY ITS ATTACHED TAG.

PARTICLES MAY BE DISCHARGED WHEN THE RUPTURE DISC RUPTURES. THESE PARTICLES MAY BE PART OF THE RUPTURE DISC ITSELF, OR OTHER ENVIRONMENTAL MATTER IN THE SYSTEM. IT IS THE USER'S SOLE RESPONSIBILITY TO ASSURE THAT THESE PARTICLES ARE DIRECTED TO A SAFE AREA TO PREVENT PERSONAL INJURY OR PROPERTY DAMAGE.

THERE IS NO GUARANTEE OF RUPTURE DISC LIFE. SUCH LIFE SPAN IS AFFECTED BY CORROSION, CREEP AND FATIGUE, AND PHYSICAL DAMAGE. THESE CONDITIONS WILL DERATE THE RUPTURE DISC TO A LOWER SET PRESSURE. THE CUSTOMER AND/OR USER SHOULD BE PREPARED TO HANDLE PREMATURE FAILURE OF THE RUPTURE DISC. THE MEDIA OR OTHER ENVIRONMENTAL CONDITIONS SHOULD NOT ALLOW ANY BUILDUP OR SOLIDIFICATION OF MEDIA TO OCCUR ON A RUPTURE DISC. THIS MAY INCREASE THE PRESSURE SETTING OF THE RUPTURE DISC.

CUSTOMER AND/OR ITS INSTALLER SHALL BE SOLELY RESPONSIBLE FOR THE PROPER INSTALLATION OF SELLER'S HOLDERS AND RUPTURE DISCS INTO A SYSTEM. CUSTOMER AND/OR ITS INSTALLER SHALL BE SOLELY RESPONSIBLE FOR IMPROPER INSTALLATION AND PHYSICAL DAMAGE RESULTING THEREFROM, INCLUDING BUT NOT LIMITED TO, DAMAGE RESULTING FROM LEAKAGE, IMPROPER TORQUING OR SEATING OF A RUPTURE DISC OR FAILURE TO FOLLOW INSTALLATION INSTRUCTIONS WHERE PROVIDED.

RUPTURE DISCS ARE PRECISION SAFETY DEVICES AND MUST BE INSTALLED PROPERLY. RUPTURE DISCS MUST BE INSTALLED BY TRAINED, KNOWLEDGEABLE INSTALLERS AND ONLY WITHIN ENVIRONMENTS SUITABLE AND APPROPRIATE FOR A RUPTURE DISC. CARE MUST BE USED IN A FACILITY'S DESIGN TO PROTECT BOTH THE RUPTURE DISC FROM INADVERTENT DAMAGE WHICH COULD CAUSE ITS PREMATURE RELEASE AND TO PROTECT INDIVIDUALS EXPOSED TO HAZARDS CREATED BY SUCH SUDDEN RELEASE.

PROPER INSTALLATION OF A RUPTURE DISC IS CRITICAL TO PERFORMANCE AND TO SAFETY. FAILURE TO PROVIDE PROPER SEATING OF A RUPTURE DISC MAY AFFECT RUPTURE DISC PERFORMANCE, BURST PRESSURE ACCURACY AND MAY RESULT IN ITS PREMATURE FAILURE.

I. Safety Precautions Before Installation

1. The ENVIRO-SEAL I rupture disc is a precision instrument and must be handled with extreme care. Rupture discs should be installed only by qualified personnel familiar with rupture discs and proper piping practices.
2. Do not install rupture disc if there is any damage evident. A damaged rupture disc is any rupture disc with visible nicks or dents.
3. Continental Disc Corporation does not recommend reinstalling a rupture disc that has been removed from the holder as reinstallation may adversely affect the joint sealing capabilities and/or performance of the rupture disc.
4. See rupture disc tag to verify set pressure, operating temperature, and all other operating parameters.

II. Preparation of Companion Flanges for Installation

New Installation

Clean all foreign material from the rupture disc sealing area of both the inlet and outlet companion flanges.

Replacement Installation

1. If the Burst Disc Indicator (B.D.I.[®]) Alarm System is used, disconnect the alarm strip from the monitor by unplugging the B.D.I. connector from the lead wire connector.
2. Remove companion flange studs and nuts and discard burst rupture disc.
3. Remove any adhered gasket material from previous installation.
4. Clean the rupture disc sealing area of both the inlet and outlet companion flanges. These surfaces must be completely clean and free of all rust, corrosion, and foreign material to ensure a proper seal. Use of solvents, steel wool, or fine emery cloth is permissible. Do not re-machine. Do not use scraper or abrasives.

III. Installation of the Rupture Disc into the System (See Figure A)

1. Before placing the rupture disc into the system, ensure that the companion flange gasket surfaces are clean and free of all rust, corrosion, and foreign material.
2. If the B.D.I. Alarm System is used, visually inspect the adhesion of the B.D.I. strip to the Teflon[®] seal and the electrical circuit. If the strip has become detached or the circuit has been broken, **DO NOT INSTALL THE RUPTURE DISC**. Ensure that the B.D.I. connector strip extends straight and flat.
3. Place the rupture disc on the inlet companion flange, as shown, centered inside the bolt holes **WITH FLOW ARROWS ON THE RUPTURE DISC TAG POINTING IN THE PROPER FLOW DIRECTION**.
4. Lower the outlet companion flange carefully onto the rupture disc using care to keep the rupture disc properly aligned.
5. NOTE: If the B.D.I. Alarm System is used, one stud approximately two inches longer than the others is needed near where the B.D.I. connector strip exits. Install lightly oiled free running studs and nuts to finger tightness. Using a cross torquing pattern (see Figure B), torque each nut with a calibrated torque wrench at 20% increments of recommended torque value (see Table 1). Repeat 20% increments and cross torquing pattern until final torque value is achieved. Recheck all nuts in rotational sequence at final torque value.
6. Use recommended torque values listed in Table 1 for bolting. These torque values are based on using gasket materials having a gasket factor of 2.75, gasket seating stress of 3,700 psi, and stud and nut material per ASME SA193-B7 and SA194-2H respectively, with a stress of up to 25,000 psi. The use of studs and nuts with lower strength may prove unsatisfactory.

* Teflon is a registered trademark of E.I. DuPont de Nemours and Company used under license.

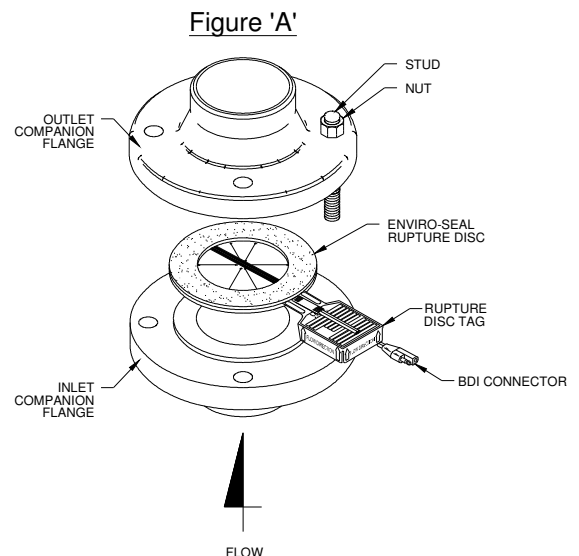
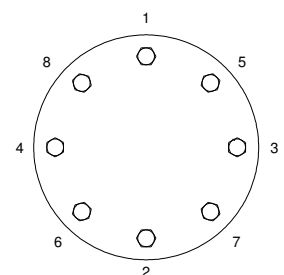
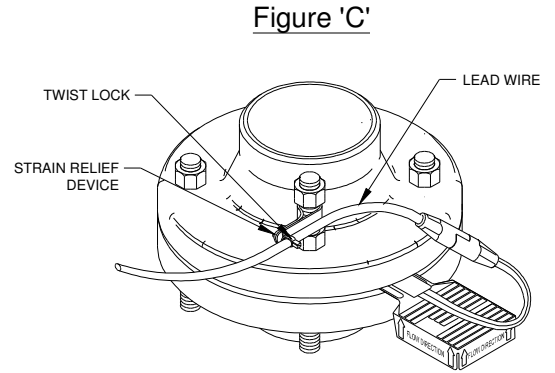

Figure 'B'
EXAMPLE OF
BOLT TORQUE SEQUENCE



8 - BOLTS

- If the B.D.I. Alarm System is used, installation of the strain relief device is necessary (see Figure C). Slip the strain relief device over the longer stud and secure with a nut. Allowing sufficient slack for easy connection to the B.D.I. connector, secure the lead wire to the strain relief device by fastening the twist lock. Plug the B.D.I. connector into the lead wire connector using a slight twisting action.



IV. Preventative Maintenance

- Risk assessment and an annual rupture disc replacement are recommended. Rupture disc service life is determined by system operating conditions. The effects of severe pressure/vacuum cycles, corrosion, temperature variations, or other adverse conditions must be evaluated by the user through actual service experience to determine optimal service life.
- IF THE RUPTURE DISC IS NOT REPLACED PERIODICALLY WHEN EXPOSED TO THESE CONDITIONS, PREMATURE FAILURE OF THE RUPTURE DISC MAY OCCUR, THEREBY DISCHARGING THE PROCESS MEDIA.**
- To avoid extended downtime, maintain three spare rupture discs in stock at all times for each holder in use. The number of spares required ultimately will be determined by service conditions.

V. Customer Service

If you wish to discuss your application, installation, or maintenance, please contact the Customer Service Department at one of the addresses shown on the last page of these instructions.

B.D.I. ALARM SYSTEM OPERATING LIMITS

TEMPERATURE: -40° F to + 400° F
(-40° C to + 204° C)

MAX CURRENT: 50 Milli Amps
MAX VOLTAGE: 24 VDC RMS

BURST DISC INDICATOR (B.D.I.®): Sizes 25mm through 900mm (1 inch through 36 inches)

Marked:  II 2 G Ex ia IIC Gb
II 2 D Ex ia IIIC Db
(Tamb = -40° C to +204° C)

EC Type Examination Certificate: ITS03ATEX 21357U

FULFILLS THE REQUIREMENTS OF DIRECTIVE 94/9/EC (ATEX) FOR: COMPONENTS of equipment and protective systems intended for use in potentially explosive atmospheres.

APPLIED HARMONIZED STANDARD: EN 60079-0:2009 General Requirements
EN 60079-11:2007 Equipment protection by intrinsic safety "i"
EN 61241-11:2006 Protection by intrinsic safety "iD"

ADDITIONAL INFORMATION: Conformity assessment performed by Notified Body no. 0359, Intertek Testing and Certification Limited, Leatherhead, Surrey, UK.

TABLE 1**Recommended Torque Values for ENVIRO-SEAL I Rupture Discs**

SIZE		COMPANION FLANGE RATING			RECOMMENDED TORQUE VALUE	
IN	MM	ANSI	DIN	JIS	FT•LB	N•m
1	25	---	6	---	15	20
1	25	150	---	---	30	41
1	25	300/600	---	10/16/20	38	52
1	25	---	10/40	---	28	38
1-1/2	40	---	6	---	28	38
1-1/2	40	150	---	---	30	41
1-1/2	40	300/600	---	---	45	61
1-1/2	40	---	10/16	10/16/20	38	52
2	50	---	6	---	26	36
2	50	150	10/16	10	35	47
2	50	300/600	---	---	17	23
2	50	---	---	16/20	18	24
2-1/2	65	---	6	---	30	41
2-1/2	65	150	---	---	40	54
2-1/2	65	300/600	---	---	24	33
3	80	---	6	---	45	61
3	80	150	10/16	---	45	61
3	80	300/600	---	---	27	37
3	80	---	---	10	23	31
3	80	---	---	16/20	28	38
3-1/2	90	150	---	---	30	41
3-1/2	90	300/600	---	---	42	57
4	100	---	6	---	67	90
4	100	150	10/16	10	35	47
4	100	300	---	---	42	57
4	100	---	---	16/20	44	60
6	150	---	6	---	50	68
6	150	150	---	---	60	81
6	150	300	---	---	40	54
6	150	---	10/16	10	63	85
6	150	---	---	16/20	46	62
8	200	---	6	---	63	85
8	200	150	---	---	75	102
8	200	300	---	---	59	80
8	200	---	10	---	79	107
8	200	---	16	10	52	70
8	200	---	---	16/20	58	79
10	250	---	6	---	54	73
10	250	150	---	---	75	102
10	250	300	---	---	64	87
10	250	---	10	---	67	91
10	250	---	---	10	74	100
10	250	---	16	16/20	81	110
12	300	---	6	---	85	116
12	300	150	---	---	95	129
12	300	300	---	---	91	123
12	300	---	10	---	85	115
12	300	---	---	10	71	96
12	300	---	16	---	103	140
12	300	---	---	16/20	77	104

TABLE 1 (continued)

Recommended Torque Values for ENVIRO-SEAL I Rupture Discs

SIZE		COMPANION FLANGE RATING			RECOMMENDED TORQUE VALUE	
IN	MM	ANSI	DIN	JIS	FT•LB	N•m
14	350	---	6	---	94	128
14	350	150	---	---	120	163
14	350	300	---	---	81	110
14	350	---	10	---	71	96
14	350	---	---	10	78	106
14	350	---	16	---	85	115
14	350	---	---	16/20	106	144
16	400	---	6	---	87	117
16	400	150	---	---	110	149
16	400	300	---	---	110	149
16	400	---	10	10	104	141
16	400	---	16	---	117	159
16	400	---	---	16/20	130	176
18	450	150	---	---	150	203
18	450	300	---	---	111	151
18	450	---	---	10	101	137
18	450	---	---	16/20	126	171
20	500	---	6	---	94	128
20	500	150	---	---	135	183
20	500	300	---	---	124	168
20	500	--	10	10	113	153
20	500	---	16	16/20	142	193
24	600	---	6	---	140	190
24	600	150	---	---	185	251
24	600	300	---	---	185	251
24	600	---	10	---	157	213
24	600	---	---	10	146	198
24	600	---	16	---	192	260
24	600	---	---	16/20	175	237
30	750	150	---	---	175	237
30	750	300	---	---	245	332
30	750	---	---	10	193	262
30	750	---	---	16	251	340
30	750	---	---	20	334	453
36	900	---	6	---	222	301
36	900	150	---	---	235	319
36	900	300	---	---	313	424
36	900	---	10	10	211	286
36	900	---	16	---	254	344
36	900	---	---	16	317	430
36	900	---	---	20	367	498



**Continental Disc[®]
Corporation**

Performance Under Pressure[®]



First Certified in 1992



ASME Code Symbol Stamp
If stamped, this product is built in accordance with the requirements of the ASME Boiler and Pressure Vessel Code, Section VIII, Division 1.

China Manufacture License
Products are in full compliance with the provisions of the Peoples Republic of China Import Regulations for Boiler and Pressure Vessel safety devices.



3A Sanitary Standards Stamp
If stamped, this product is in full compliance with the 3A standards, Serial #60-00, of the International Association of Milk, Food, and Environmental Sanitarians, Inc.



European Union CE Mark
If stamped, this product is certified to conform to the essential requirements of the Pressure Equipment Directive.

Continental Disc Corporation has representatives located throughout the world.
Contact the office nearest you for the authorized representative in your area.



HEADQUARTERS //
3160 W. Heartland Drive
Liberty, MO 64068 USA
Ph (816) 792 1500 | Fax (816) 792 2277
sales@contdisc.com

contdisc.com

THE NETHERLANDS
Energieweg 20
2382 NJ Zoeterwoude-Rijndijk
The Netherlands
Ph +(31) 71 5412221 | Fax +(31) 71 5414361
cdcnl@contdisc.com

CHINA
Room 910, Tower B, COFCO Plaza
No. 8 JianGuoMenNei Avenue
Beijing (100005), P.R. China
Ph +(86) 10 522 4885 | Fax +(86) 10 6522 2885
cdcchina@contdisc.com

INDIA
423/P/11, Mahagujarat Industrial Estate, Moraiya,
Sarkhej-Bavlra Road, Ahmedabad (GJ)
382213 INDIA
Ph +(91) 2717 619 333 | Fax +(86) 10 6522 2885
gcmpl@contdisc.com

Continental Disc Corporation reserves the right to alter the information in this publication without notice.

Reproduction without written permission prohibited.

©2001, 2003, 2004, 2008, 2009, 2010, 2011 Continental Disc Corporation

Printed in U.S.A.