



Continental Disc Corporation

Performance Under Pressure®

Tite-Seal and Screw Type Assemblies

Continental Disc Corporation's Tite-Seal and Screw Type assemblies are complete rupture disc and holder units specifically designed for use on various types of pressurized "mini systems" such as:

- Air conditioning systems
- Refrigeration units
- Hydraulic accumulators
- Gas cylinders
- Portable compressed air systems
- Laboratory equipment

Tite-Seal and Screw Type assemblies provide dependable, instantaneous overpressure relief for protecting systems, equipment and vessels from potentially damaging excess pressure conditions. Tite-Seal and Screw Type assemblies are available with a variety of inlet and outlet connections to accommodate various applications.

Tite-Seal Assembly

The Tite-Seal assembly is a sealed, disposable unit for use in systems where pressures do not exceed 3,000 psig (207 barg). The Tite-Seal assembly features a rupture disc sealed between brass fittings. After relieving an overpressure condition, changeout is easily performed by replacing the entire assembly. Continental Disc Corporation's Tite-Seal assembly can be supplied with a Standard, Composite or SRA rupture disc (see page 5) to accommodate various applications.

Screw Type Assembly

Continental Disc Corporation's Screw Type assembly is a reusable unit for use in systems with pressures up to 15,000 psig (1034 barg). A Standard or Composite rupture disc is supplied separately from the Screw Type holder. After an overpressure condition occurs, changeout is accomplished by disassembling the Screw Type holder and replacing only the burst rupture disc.

Various pressure ratings, materials and holder configurations are available to customize the Screw Type assembly to your specific application.



Tite-Seal Assembly



Screw Type Assembly

Standard (STD) Rupture Disc for Tite-Seal or Screw Type Holders

The Standard Rupture Disc is a differential pressure relief device which provides instantaneous overpressure protection. For Tite-Seal and Screw Type holders, this Standard rupture disc, designated STD, is a 1/2", 3/4" and 1" preformed, solid metal design.

STD Rupture Disc Features:

- Operation to 70% of the rupture disc's rated burst pressure
- Availability of a wide range of corrosion resistant materials
- Instantaneous full opening
- Compatible in systems with operating temperatures up to 1,000°F (542°C) (see Table III)

- Applicable in liquid or gas media
- Burst pressures ranging from 29 to 15,000 psig (2,00 to 1034 barg), depending on rupture disc material and holder type (see Table IV)

The Standard rupture disc is available in Aluminum, Silver, Nickel, 316 SS, MONEL®, INCONEL® and HASTELLOY® C materials. Other materials are available upon request.

OPTIONS: Various options including TEFLON® coating, a gasket, a protective ring or a vacuum support can be added to customize the Standard rupture disc to fit your specific application.

STANDARD AND COMPOSITE RUPTURE DISCS

TEFLON® coating, applied to the process or vent side of the rupture disc, helps shield the rupture disc from atmospheric or process media corrosives (Aluminum STD rupture discs are TEFLON® coated on each side, as a standard). A gasket of TFE, PFA, or FEP TEFLON® may be added to the inlet side of the rupture disc to enhance sealing.

A **protective ring** added to the inlet or outlet side of the rupture disc provides additional seating area protection to thinner material rupture discs. Unless otherwise specified, the protective ring is supplied in the same material as specified for the rupture disc. Also, some low pressure Standard rupture discs require support for backpressure or vacuum conditions, therefore, depending upon specific operating conditions, a **vacuum support** may be supplied. Available vacuum support materials include 316 SS, Monel®, Nickel or Inconel®. Please consult your Continental Disc Corporation representative or the factory when vacuum or backpressure conditions are present.

For Tite-Seal Holders

For the Tite-Seal holder, the Standard rupture disc is a flat seat design with burst pressures ranging from 29 to 3,000 psig (2,00 to 207 barg). Refer to Table IV for the minimum and maximum burst pressures for STD rupture discs.

For Screw Type Holders

For Screw Type holders, the Standard rupture disc is:

- a 30° angular “Light Lip” seat design for pressures up to 3,000 psig (207 barg)
- a flat seat design for burst pressures up to 10,000 psig (689 barg)
- a high pressure flat seat design for burst pressures up to 15,000 psig (1034 barg)

Composite (CDCV-G) Rupture Disc for Tite-Seal or Screw Type Holders

Continental Disc Corporation’s Composite rupture disc is a differential pressure relief device that provides instantaneous, full opening overpressure protection. For Tite-Seal and Screw Type holders, this Composite rupture disc, designated CDCV-G, is an 11/16”, pre-formed, flat seat rupture disc.

Table I - 11/16” Composite Rupture Disc (CDCV-G) Material Selection Information

TOP SECTION	VACUUM SUPPORT	SEAL	GASKET
HASTELLOY® C	HASTELLOY® C	TEFLON® OR SILVER	CHEMFILM
MONEL®	316 SS		
NICKEL	316 SS		
INCONEL® 316 SS	316 SS		

11/16” CDCV-G Rupture Disc Features:

- Operation to 80% of the rupture disc’s rated burst pressure
- Support for full vacuum conditions, -14.7 psig (-1,01 barg)
- Compatible in systems with operating temperatures up to 400°F (204°C). (See Table III)
- Applicable in liquid or gas media with static, cyclic or pulsating pressure conditions
- Burst pressures ranging from 30 to 1,000 psig (2,07 to 68,9 barg) depending upon rupture disc material. (See Table IV)

The 11/16” Composite Rupture Disc consists of a metallic top section, an integral seal, metal vacuum support, and CHEMFILM® gasket. The metallic top section is available in Nickel, 316 SS, Monel®, Inconel® and Hastelloy® C materials. Other materials are avail-

able upon request. Depending upon the rupture disc’s top section material, the vacuum support will be constructed from either 316 SS or Hastelloy® C. (See Table I.)

The rupture disc’s seal material is available in either TEFLON® or silver to accommodate various operating conditions. TEFLON® is supplied unless otherwise specified.

For Tite-Seal and Screw Type Holders

The 11/16” Composite rupture disc may be used in either Tite-Seal or flat seat Screw Type holders. It is recommended for applications where the maximum

burst pressure does not exceed 1,000 psig (68,9 barg).

Manufacturing Range

The manufacturing range of a rupture disc is defined as the allowable pressure range within which a rupture disc is rated. The manufacturing range is based upon the customer’s requested burst pressure. The manufacturing ranges for the Standard and 11/16” Composite rupture discs appear in Table II.

Burst Tolerance

The burst tolerance of a rupture disc is the maximum expected burst pressure variation from the rupture disc’s rated (stamped) burst pressure. The burst tolerance for Standard and 11/16” Composite rupture discs is ±2 psig for pressures up to and including 40 psig and ±5% for pressures above 40 psig. Burst tolerance is applied to the stamped rating of the rupture disc.

Temperature

In general, as temperature increases burst pressure decreases. Refer to Table III for the recommended maximum temperature for common rupture disc and seal materials.

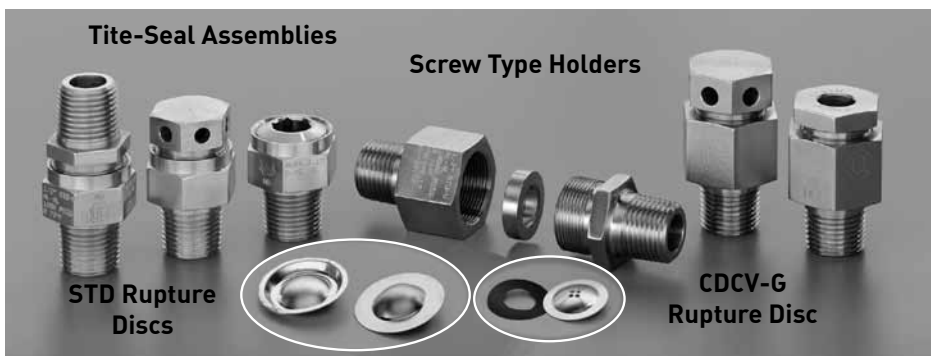

SPECIFICATIONS

Code Compliance

Continental Disc Corporation will provide Tite-Seal and Screw Type assemblies to national or international code requirements when specified by the customer. Continental Disc Corporation will manufacture, temperature test, and mark rupture discs in compliance with the requested code. Product may be supplied to ASME Section III or VIII, ISO, DIN, EN, BSI, JIS, or other codes as requested.

Continental Disc Corporation has been accredited and is authorized by the ASME Code to utilize the Code Symbol Stamp for product built in accordance with the requirements of the ASME Boiler and Pressure Vessel Code, Section VIII, Division 1.

The certified flow resistance value (K_R) and minimum net flow area value of the Tite-Seal assembly and the Screw Type assembly are available from Continental Disc Corporation's CERTIFLOW® literature at www.contdisc.com.

Continental Disc Corporation maintains an ASME accepted flow laboratory to conduct flow testing for rupture discs, relief valves, and rupture disc/valve combinations.

Tite-Seal Assembly

The Tite-Seal holder, used with a Standard or Composite rupture disc, consists of three brass components: 1) an inlet, 2) an outlet, 3) a holddown ring.

The inlet component is available in 1/4", 3/8", 1/2", 3/4" and 1" male pipe threading (MPT). The outlet component is available in five configurations to match the requirement of your application. (See Table V)

After the rupture disc is installed in the Tite-Seal holder, the inlet and outlet components are permanently affixed to provide a SEALED ASSEMBLY. When an overpressure condition occurs, THE ENTIRE ASSEMBLY CAN BE QUICKLY REMOVED and replaced with a new assembly.

Table II - Manufacturing Range for Standard and 11/16" Composite Rupture Discs

SPECIFIED BURST PRESSURE		MANUFACTURING RANGE: %	
psig	barg	UNDER	OVER
MIN - 50	MIN - 3,45	-4	14
51 - 100	3,52 - 6,89	-4	10
101 - 500	6,96 - 34,5	-4	7
ABOVE 500	ABOVE 34,5	-3	6

Table III - Maximum Recommended Temperature for Common Rupture Disc and Seal Materials

RUPTURE DISC TYPE	MATERIAL	°F	°C
STD	Aluminum / Silver	260	127
	Nickel / Monel®	800	427
	316 SS / Hastelloy® C	900	482
	Inconel®	1,000	538
11/16" CDCV-G SEAL	Teflon®/ Silver	400	204

Table IV - Minimum / Maximum Burst Pressures for 11/16" Composite (CDCV-G) and Standard (STD) Rupture Discs

RUPTURE DISC TYPE	RUPTURE DISC MATERIAL	BURST PRESSURE MINIMUM / MAXIMUM psig @ 72°F / barg @ 22°C				RUPTURE DISC TYPE	RUPTURE DISC MATERIAL	BURST PRESSURE MINIMUM / MAXIMUM psig @ 72°F / barg @ 22°C			
		MINIMUM		MAXIMUM				MINIMUM		MAXIMUM	
		psig	barg	psig	barg			psig	barg	psig	barg
11/16" CDCV-G with Teflon Seal	Nickel	30	2,07	490	33,8	3/4" STD	Aluminum	47	3,24	1000	68,9
	Monel®	30	2,07	615	42,4		Silver	140	9,65	1000	68,9
	316 SS	40	2,76	740	51,0		Nickel	225	15,5	1000	68,9
	Inconel®	40	2,76	760	52,4		Monel®	265	18,3	1000	68,9
	Hastelloy® C	100	6,89	1,000	68,9		316 SS	590	40,7	1000	68,9
11/16" CDCV-G with Silver Seal	Nickel	375	25,9	715	49,3	Inconel®	320	22,1	1000	68,9	
	Monel®	375	25,9	845	58,3	1" STD	Aluminum	29	2,00	1000	68,9
	316 SS	375	25,9	1,000	68,9		Silver	140	9,65	1000	68,9
	Inconel®	375	25,9	1,000	68,9		Nickel	150	10,3	1000	68,9
	Hastelloy® C	475	32,8	1,000	68,9		Monel®	180	12,4	1000	68,9
1/2" STD	Aluminum	65	4,48	1,500	103		316 SS	420	29,0	1000	68,9
	Silver	220	15,2	1,500	103	Inconel®	250	17,2	1000	68,9	
	Nickel	300	20,7	6,000	414						
	Monel®	350	24,1	6,000	414						
	316 SS	760	52,4	15,000	1034						
	Inconel®	560	38,6	15,000	1034						

TITE-SEAL ASSEMBLY

Tite-Seal Holder Specifications

Maximum Pressure:.....3,000 psig
(207 barg)

Maximum Temp.:400°F
(204°C)

Materials:All brass components

Two Tite-Seal holder configurations are available. The 1,000 psig design is compatible with either a Standard or Composite rupture disc, up to a maximum 1,000 psig (68,9 barg) burst pressure. A 3,000 psig (207 barg) unit is available for applications where burst pressures exceed 1,000 psig. This unit is compatible with a ½", ¾" or 1" Standard rupture disc. Refer to Table V for Tite-Seal assembly configurations, weights and dimensions.

The maximum temperature limits of the Tite-Seal holder are dependent upon the limitations of either the rupture disc or the holder. In the case of the maximum allowable temperature, use the lesser limit of the two.

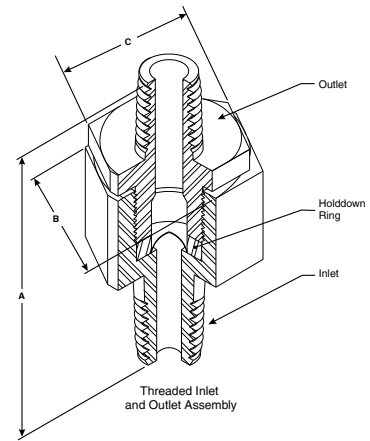
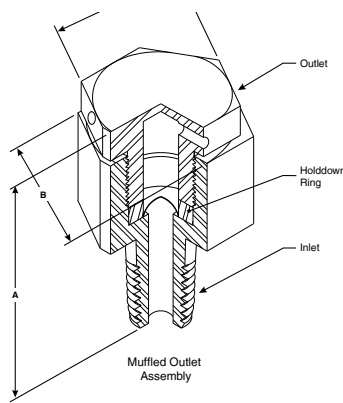
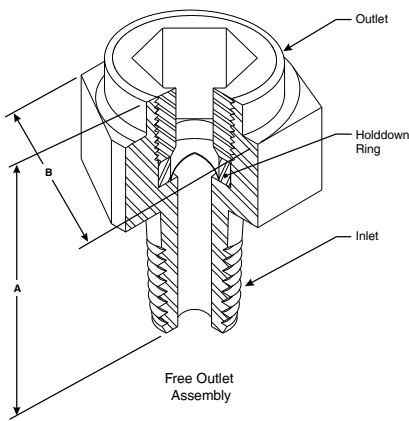

Table V - Tite-Seal Assembly Specifications, Weights and Dimensions

HOLDER CONNECTIONS		UNIT WEIGHT				OVERALL HEIGHT (A)				DIMENSIONS ACROSS HEX FLATS							
		1000# Assembly		3000# Assembly		1000# Assembly		3000# Assembly		INLET (B)				OUTLET (C)			
		lbs.	kgs.	lbs.	kgs.	in.	mm.	in.	mm.	1000# Assembly	3000# Assembly	1000# Assembly	3000# Assembly	1000# Assembly	3000# Assembly	1000# Assembly	3000# Assembly
¼" MPT	¼" MPT	0.27	0,122	0.32	0,145	2.12	53,8	2.27	57,7								
"	⅜" MPT	0.28	0,127	0.33	0,150	2.16	54,9	2.31	58,7								
"	½" MPT	0.30	0,136	0.35	0,159	2.31	58,7	2.45	62,2	1.13	28,7	1.25	31,8	1.00	25,4	1.00	25,4
"	MUFFLED	0.25	0,113	0.30	0,136	1.81	46,0	1.95	49,5								
"	FREE	0.20	0,091	0.25	0,113	1.34	34,0	1.49	37,8								
⅜" MPT	⅜" MPT	0.29	0,132	0.34	0,154	2.19	55,6	2.34	59,4								
"	½" MPT	0.31	0,141	0.36	0,163	2.34	59,4	2.49	63,2	1.13	28,7	1.25	31,8	1.00	25,4	1.00	25,4
"	MUFFLED	0.26	0,118	0.31	0,141	1.84	46,7	1.99	50,5								
"	FREE	0.21	0,095	0.26	0,118	1.37	34,8	1.53	38,9								
½" MPT	½" MPT	0.34	0,154	0.39	0,177	2.50	63,5	2.50	63,5								
"	MUFFLED	0.29	0,132	0.34	0,154	2.00	50,8	2.01	51,1	1.13	28,7	1.25	31,8	1.00	25,4	1.00	25,4
"	FREE	0.24	0,109	0.29	0,132	1.53	38,9	1.54	39,1								
¾" MPT	¾" MPT	0.38	0,172	-	-	3.07	78,0	-	-	1.25	31,8	-	-	1.13	28,7	-	-
¾" MPT	MUFFLED	0.33	0,150	-	-	2.66	67,6	-	-	1.25	31,8	-	-	1.00	25,4	-	-
¾" MPT	FREE	0.30	0,136	-	-	2.29	58,2	-	-	1.25	31,8	-	-	N/A	N/A	-	-
1" MPT	1" MPT	1.12	0,508	-	-	3.19	81,0	-	-	2.00	50,8	-	-	2.00	50,8	-	-
1" MPT	MUFFLED	1.24	0,562	-	-	2.50	63,5	-	-	2.00	50,8	-	-	2.00	50,8	-	-
1" MPT	FREE	1.12	0,508	-	-	2.25	57,2	-	-	2.00	50,8	-	-	2.00	50,8	-	-

SRA Assembly with 1/2", 3/4" or 1" Scored Reverse Acting Rupture Disc

The SRA assembly, manufactured under an ISO 9001 Certified Quality Assurance System, is a sealed unit engineered for quick changeout. This unit incorporates a 1/2", 3/4" or 1" scored reverse acting rupture disc which utilizes Continental Disc Corporation's failure initiating indent and a Tite-Seal holder.

After overpressure relief occurs, the entire unit is thrown away and replaced with a new assembly. The SRA assembly is specifically designed for use on pressurized "mini-systems" such as;

- air conditioning systems,
- refrigeration units,
- hydraulic accumulators,
- gas cylinders,
- portable compressed air systems,
- high pressure water power cleaning systems,
- laboratory equipment,
- where pressures do not exceed 1000 psig (68,9 barg) but system operation requires the rupture disc to withstand pressures up to 90% of its burst rating.

The permanently sealed SRA assembly offers several important features:

- Solid metal rupture disc with Precision Semicircular Score that provides a non-fragmenting, full open, pressure relief pattern.
- Continental Disc Corporation's Failure Initiating Indent, a highly accurate method to achieve and control burst pressure at close tolerances.
- System operation to 90% of the rupture disc's rated burst pressure under static or cyclic service conditions.
- Can be installed in gaseous systems. Consult factory for liquid system application.
- Standard manufacturing ranges include:
 - 5 psig for burst pressure ratings below 50 psig
 - 10% for rated burst pressures 50 psig and above
- Inherent with most reverse acting type rupture discs on the market, the SRA assembly is capable of operating in full vacuum applications without an additional vacuum support component compared to tension type rupture discs.
- Meets leak rate specifications up to 4 x 10⁻⁹ ATM cc/second Helium.

- Solid metal construction provides leakage and permeation control especially when stringent leak rate levels are required.
- Non-fragmenting design makes unit ideal for isolating safety relief valves.
- Burst Tolerance: ± 2 psig for burst pressures ≤ 40 psig, ± 5% for burst pressures > 40 psig. (The rated burst pressure is stamped on the body)
- Operating Conditions:
 - Pressure: 90% operating-to-burst pressure ratio for pressures > 40 psig. For pressures ≤ 40 psig, 90% ratio applies to the burst pressure minus the burst tolerance [(stamped rating - 2 psig burst tolerance) x .90].
 - Temperature: -40°F to 400°F (Temperatures may be limited by O-ring material. See chart.) (-40°C to 204°C)
- Materials: The SRA holder assembly consists of all brass parts. Available rupture disc and O-ring materials as shown in chart below. Other materials available upon request.
- Specifications - See Table VI.
- Standard Connections: (Others available upon request)
 - Inlet: 1/4", 3/8", 1/2", 3/4" and 1" NPT
 - Outlet: Free, Muffled, 1/2", 3/4", and 1" NPT

Table VI - SRA Assembly Specifications

1/2" Rupture Disc Material	BURST PRESSURE MINIMUM / MAXIMUM psig @ 72°F / barg @ 22°C				3/4" Rupture Disc Material	BURST PRESSURE MINIMUM / MAXIMUM psig @ 72°F / barg @ 22°C				1" Rupture Disc Material	BURST PRESSURE MINIMUM / MAXIMUM psig @ 72°F / barg @ 22°C			
	Minimum		Maximum			Minimum		Maximum			Minimum		Maximum	
	psig	barg	psig	barg		psig	barg	psig	barg		psig	barg	psig	barg
Aluminum	18	1,24	350	24,1	Aluminum	19	1,31	230	15,9	Aluminum	13	0,90	175	12,1
Nickel	45	3,10	1000	68,9	Nickel	35	2,41	1000	68,9	Nickel	27	1,86	1000	68,9
Monel®	45	3,10	1000	68,9	Monel®	35	2,41	1000	68,9	Monel®	27	1,86	1000	68,9
316SS	120	8,27	1000	68,9	316SS	50	3,45	1000	68,9	316SS	50	3,45	1000	68,9
Inconel®	120	8,27	1000	68,9	Inconel®	50	3,45	1000	68,9	Inconel®	50	3,45	1000	68,9
Hastelloy C-276®	125	8,62	1000	68,9	Hastelloy C-276®	85	5,86	1000	68,9	Hastelloy C-276®	55	3,79	1000	68,9

O-Ring Materials	Temperature Limits	
	Degrees F	Degrees C
Black Buna-N (standard)	-40° – 225°	-40° – 107°
Black Neoprene	-45° – 250°	-43° – 121°
Black VITON®	-20° – 400°	-29° – 204°
Teflon®	-40° – 400°	-40° – 232°

SCREW TYPE HOLDER

Screw Type Holder

The Screw Type holder used with the Standard or Composite rupture disc consists of three components: 1) an inlet, 2) an outlet, 3) a holddown ring.

The inlet component is available in 1/4" or 1/2" MPT. Outlet components are offered in 1/2" MPT, muffled, or free venting configurations.

The Screw Type holder is available with the inlet, outlet, and holddown ring constructed from 316 SS or with a 316 SS inlet and Carbon Steel outlet and holddown ring. When ordering, please specify the combination of materials required for your application.

The Screw Type holder is a reusable unit; after an overpressure condition occurs, disassemble the unit and replace only the burst rupture disc.

Screw Type Holder Specifications

Maximum Pressure:..... 15,000 psig
(1034 barg)

Maximum Temp: 1,000°F
(538°C)

Materials:

Inlet:.....316 SS

Outlet: 316 SS or
Carbon Steel

Ring:..... 316 SS or
Carbon Steel

The maximum temperature limits of the Screw Type holder are dependent upon the limitations of either the rupture disc or the holder. In the case of the maximum allowable temperature, use the lesser limit of the two.

Note:

The 11/16" CDCV-G rupture disc with its matching holddown ring and the 1/2" STD rupture disc with its matching holddown ring utilize the same 10,000 psig holder inlet and outlet. These rupture discs, together with their respective holddown rings, are interchangeable in the 10,000 psig Screw Type holder.

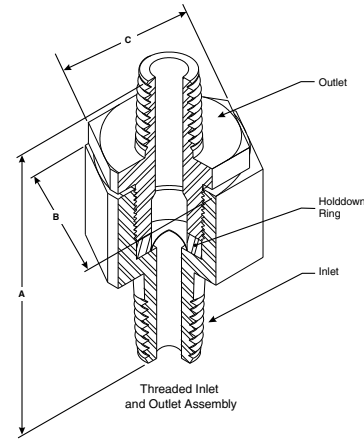
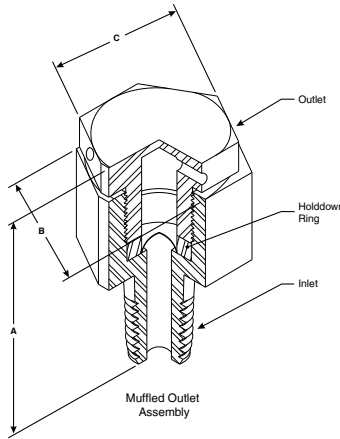
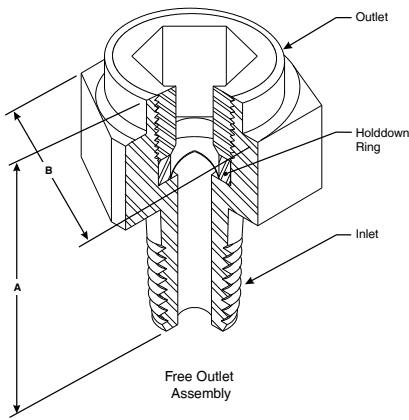

Table VII - Screw Type Holder Specifications, Weights and Dimensions

MAXIMUM PRESSURE @ 72°F (22°C)	HOLDER ASSEMBLY NUMBER FOR:		SEAT STYLE	HOLDER CONNECTION		UNIT WEIGHT		OVERALL HEIGHT (A)		DIMENSIONS ACROSS HEX FLATS			
	1/2" STD	11/16" CDCV-G		INLET	OUTLET	lbs	kgs	in	mm	INLET (B)		OUTLET (C)	
										in	mm	in	mm
3,000 psig 207 barg	S01	--	30° LIGHT LIP	1/4 MPT	FREE	0.47	0,213	2.20	55,9	1.25	31,8	1.13	28,7
	S02	--	"	1/2 MPT	FREE	0.47	0,213	2.26	57,4				
	S03	--	"	1/4 MPT	1/2 MPT	0.53	0,240	2.98	75,7				
	S04	--	"	1/2 MPT	1/2 MPT	0.53	0,240	3.04	77,2				
	S05	--	"	1/4 MPT	MUFFLED	0.48	0,218	2.45	62,2				
	S06	--	"	1/2 MPT	MUFFLED	0.48	0,218	2.51	63,8				
10,000 psig 689 barg	S11	S51	FLAT SEAT	1/4 MPT	FREE	0.41	0,186	2.03	51,6	1.25	31,8	1.13	28,7
	S12	S52	"	1/2 MPT	FREE	0.44	0,200	2.03	51,6				
	S13	S53	"	1/4 MPT	1/2 MPT	0.47	0,213	2.81	71,4				
	S14	S54	"	1/2 MPT	1/2 MPT	0.50	0,227	2.81	71,4				
	S15	S55	"	1/4 MPT	MUFFLED	0.45	0,204	2.28	57,9				
	S16	S56	"	1/2 MPT	MUFFLED	0.48	0,218	2.28	57,9				
15,000 psig 1034 barg	S23	--	FLAT SEAT	1/4 MPT	1/2 MPT	0.47	0,213	2.81	71,4	1.25	31,8	1.13	28,7
	S24	--	"	1/2 MPT	1/2 MPT	0.50	0,227	2.81	71,4				
	S25	--	"	1/4 MPT	MUFFLED	0.47	0,213	2.34	59,4				
	S26	--	"	1/2 MPT	MUFFLED	0.50	0,227	2.34	59,4				

Please provide the following information when ordering. Order holder and rupture disc separately.

Rupture Disc¹

Continental Disc Corporation Standard (STD) Rupture Disc

Quantity: _____ Description: 1/2", 3/4" or 1" STD rupture disc

Material: _____ (See Table IV or consult Continental Disc Corporation)

Rated Burst Pressure: _____ psig or barg @ _____ °F or °C

Manufacturing Range: _____

Manufacturing Number: _____ (if replacing previously supplied Continental Disc Corporation rupture disc)

- Options:
- Coating
 - Gasket
 - Protective rings
 - Vacuum support

Continental Disc Corporation Composite (CDCV-G) Rupture Disc

Quantity: _____ Description: 11/16" CDCV-G rupture disc

Material: _____ Top Section (See Table IV or consult Continental Disc Corporation)

_____ Seal (Specify Teflon® or Silver Teflon® is standard.)

_____ Vacuum Support² (Specify 316 SS or Hastelloy® C)

Chemfilm Gasket

Rated Burst Pressure: _____ psig or barg @ _____ °F or °C

Manufacturing Range: _____

Manufacturing Number: _____ (if replacing previously supplied Continental Disc Corporation rupture disc)

Holder

Tite-Seal Holder

Quantity: _____ Description: Specific holder connections and pressure rating.

Maximum System Operation Pressure @ 72°F: _____

Material: Brass Inlet, Holddown Ring, and Outlet

Screw Type Holder

Quantity: _____ Description: Screw Type⁴ _____ rupture disc holder

Maximum System Operation Pressure @ 72°F: _____

Material: Inlet: 316 SS

Holddown Ring: _____ ⁵ (Specify 316 SS or Carbon Steel)

Outlet: _____ ⁵ (Specify 316 SS or Carbon Steel)

Notes:

- 1 When ordering a rupture disc without a holder:
 - a. provide the previous rupture disc manufacturing number or;
 - b. order the matching holddown ring for the ordered rupture disc.
- 2 Vacuum support material: Specify HASTELLOY® C when top section is HASTELLOY® C, otherwise specify 316 SS.
- 3 Please specify holder assembly number corresponding to inlet and outlet connection required. Refer to Table VI for Screw Type holders.
- 4 Specify same material for holddown ring and holder outlet: 316 SS or Carbon Steel.

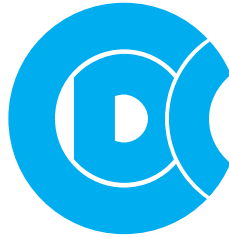

Continental Disc[®] Corporation

Performance Under Pressure[®]



ASME Code Symbol Stamp
Available When Specified



China Manufacture License
Available When Specified



Pressure Equipment Directive
Available When Specified

Continental Disc Corporation has representatives located throughout the world.
Contact the Continental Disc Corporation office nearest you for the authorized representative in your area.

CORPORATE HEADQUARTERS

Continental Disc Corporation
3160 W. Heartland Drive
Liberty, MO 64068-3385 USA

Phone: (816) 792-1500
FAX: (816) 792-2277/5447
E-mail: pressure@contdisc.com
Website: www.contdisc.com

THE NETHERLANDS

Continental Disc Corporation
Energieweg 20
2382 NJ Zoeterwoude-Rijndijk
The Netherlands

Phone: + (31) 71-5412221
FAX: + (31) 71-5414361
E-mail: cdcnl@contdisc.com

CHINA

Continental Disc Corporation
Room 910, Tower B, COFCO Plaza
No. 8 JianGuoMenNei Avenue
Beijing (100005), P.R. China

Phone: + (86) 10-6522-4885
Fax: + (86) 10-6522-2885
Mobile: + (86) 137-0103-8871
E-mail: cdcchina@contdisc.com

INDIA

Continental Disc Corporation
Survey No. 423/P, Mahagujarat
Industrial Estate, Moraiya, Sarkhej-
Bavla Road, Ahmedabad 382213,
INDIA

Phone: +91 2717 619 333
FAX: +91 2717 619 345
E-mail: gcmpl@contdisc.com

TEFLON[®] is a registered trademark of DuPont used under license by Continental Disc Corporation.
HASTELLOY[®] is a registered trademark of Haynes International.
VITON[®] is a registered trademark of DuPont Performance Plastics.

INCONEL[®] and MONEL[®] are registered trademarks of the Inco family of companies.
CHEMFILM[®] is a registered trademark of Saint-Gobain Performance Plastics Corporation.