

**Continental Disc[®]
Corporation**

WELL ACTIVATION AND SAFETY PROTECTION VALVE - TYPE A

for Downhole Drilling Applications



Continental Disc Corporation introduces the new **Well Activation and Safety Protection Valve**. The Well Activation and Safety Protection Valve is designed to release pressure to activate tools already in the hole or to protect downhole drill components from overpressure failure. The Well Activation and Safety Protection Valve uses rupture disc technology to achieve high accuracy and reliability. It can replace shear pins and other moving devices in most applications

and saves valuable time and labor on the drill site.

The Well Activation and Safety Protection Valve is offered in two configurations, Type A and Type I, depending on required burst direction. Type A can prevent dangerous pressure spikes from the annulus.

Industries/Applications:

- Protect drill pipe and casing from collapse or burst from overpressure scenarios
- Trigger the release of fishing grapples and releasable spears
- Activate controls in the bottom hole assembly (BHA)
- Activate tools down the hole in sequential stages
- Many other applications during drilling, cementing, perforating, completion and production

Materials (standard component materials shown below, other materials available upon request):

Rupture Disc:

- Inconel^{®1} 600

Holder Body Inlet and Outlet:

- 316 SS

O-Ring:

- Viton^{®2}

Specifications:

- Burst Pressure Available From: 1000 psig – 14500 psig in 500 psi increments. Other burst pressures available upon request. (See Table 1 for standard pressures and temperatures.)
- Maximum temperature up to 450°F. Other temperatures available upon request.
- Performance Tolerance:
 - ±100 psig for burst pressures 1000 - 5000 psig
 - ± 2% of burst pressure >5000 psig.
- Operating Pressure up to 90% of Specified Burst Pressure

¹ Inconel[®] is a registered trademark of the Inco family of companies.

² Viton is a registered trademark of DuPont.

Industry Standards/Certifications:

- Continental Disc Corporation has maintained a certified ISO 9001 Quality Management System since 1992.
- Product demonstrations, specification validation, and source inspection can be arranged upon request.

Features of the Well Activation and Safety Protection Valve:

- Simple pressure activation
- Accurate, reliable, and consistent rupture disc performance
- Quick opening safety valve has response time under five milliseconds
- Rugged and reliable design



Benefits:

- Fast delivery keeps your operation running smoothly and on time. Standard lead times from one to four weeks
- Simple pressure activation allows operators to activate downhole tools and devices at any depth without having to rely on pyrotechnics, electronic signals, or mechanical systems.
- Easily replaceable parts save valuable drilling and production time by reducing down-time.
- The Type A Well Activation and Safety Protection Valve can be used to protect drill pipes, casings or even downhole tools from over-pressure. Helps prevent catastrophic pressure spikes from the annulus that can damage equipment and kill the well.
- The disc is designed to be self-protecting, minimizing damage by down-hole debris during trips.

The Well Activation and Safety Protection Valve is engineered for downhole drilling applications involving all aspects of making the hole - exploration, drilling, completion and production.

For more information on the Well Activation and Safety Protection Valve and other Continental Disc Corporation products, please contact your local representative or visit our website at www.contdisc.com.

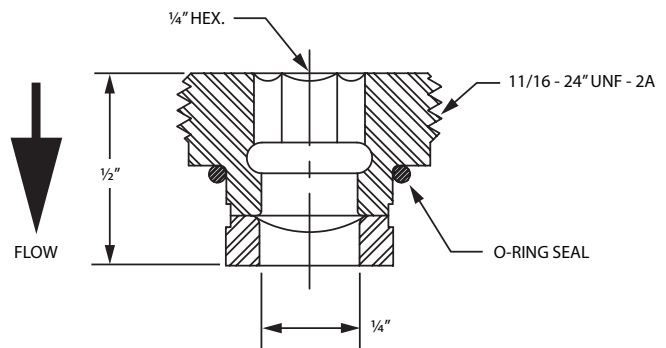

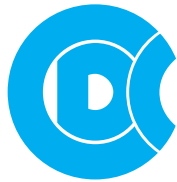

**Continental Disc
Corporation**

WELL ACTIVATION AND SAFETY PROTECTION VALVE - TYPE A

for Downhole Drilling Applications (continued)

Table 1 – List of Standard Burst Pressures and Temperatures (Type A)

Part Number	Specified Burst Pressure at Temperature (psig)	Burst Pressure at Temperature (psig)							
		100°F	150°F	200°F	250°F	300°F	350°F	400°F	450°F
WSP-A01	1,000 @ 100°F	1,000	980	960	949	939	929	929	919
WSP-A02	1,500 @ 100°F	1,500	1,470	1,439	1,424	1,409	1,394	1,394	1,379
WSP-A03	2,000 @ 100°F	2,000	1,960	1,919	1,899	1,879	1,859	1,859	1,838
WSP-A04	2,500 @ 100°F	2,500	2,449	2,399	2,374	2,348	2,323	2,323	2,298
WSP-A05	3,000 @ 100°F	3,000	2,939	2,879	2,848	2,818	2,788	2,788	2,758
WSP-A06	3,500 @ 100°F	3,500	3,429	3,359	3,323	3,288	3,253	3,253	3,217
WSP-A07	4,000 @ 100°F	4,000	3,919	3,838	3,798	3,758	3,717	3,717	3,677
WSP-A08	4,500 @ 100°F	4,500	4,409	4,318	4,273	4,227	4,182	4,182	4,136
WSP-A09	5,000 @ 150°F	5,103	5,000	4,897	4,845	4,794	4,742	4,742	4,691
WSP-A10	5,500 @ 150°F	5,613	5,500	5,387	5,330	5,273	5,216	5,216	5,160
WSP-A11	6,000 @ 150°F	6,124	6,000	5,876	5,814	5,753	5,691	5,691	5,629
WSP-A12	6,500 @ 150°F	6,634	6,500	6,366	6,299	6,232	6,165	6,165	6,098
WSP-A13	7,000 @ 200°F	7,295	7,147	7,000	6,926	6,853	6,779	6,779	6,705
WSP-A14	7,500 @ 200°F	7,816	7,658	7,500	7,421	7,342	7,263	7,263	7,184
WSP-A15	8,000 @ 200°F	8,337	8,168	8,000	7,916	7,832	7,747	7,747	7,663
WSP-A16	8,500 @ 200°F	8,858	8,679	8,500	8,411	8,321	8,232	8,232	8,142
WSP-A17	9,000 @ 200°F	9,379	9,189	9,000	8,905	8,811	8,716	8,716	8,621
WSP-A18	9,500 @ 250°F	10,005	9,803	9,601	9,500	9,399	9,298	9,298	9,197
WSP-A19	10,000 @ 250°F	10,532	10,319	10,106	10,000	9,894	9,787	9,787	9,681
WSP-A20	10,500 @ 250°F	11,059	10,835	10,612	10,500	10,388	10,277	10,277	10,165
WSP-A21	11,000 @ 250°F	11,585	11,351	11,117	11,000	10,883	10,766	10,766	10,649
WSP-A22	11,500 @ 250°F	12,112	11,867	11,622	11,500	11,378	11,255	11,255	11,133
WSP-A23	12,000 @ 300°F	12,774	12,516	12,258	12,129	12,000	11,871	11,871	11,742
WSP-A24	12,500 @ 450°F	13,599	13,324	13,049	12,912	12,775	12,637	12,637	12,500
WSP-A25	13,000 @ 450°F	14,143	13,857	13,571	13,429	13,286	13,143	13,143	13,000
WSP-A26	13,500 @ 350°F	14,527	14,234	13,940	13,793	13,647	13,500	13,500	13,353
WSP-A27	14,000 @ 350°F	15,065	14,761	14,457	14,304	14,152	14,000	14,000	13,848
WSP-A28	14,500 @ 350°F	15,603	15,288	14,973	14,815	14,658	14,500	14,500	14,342

Bold type indicates specified burst pressure. Regular type indicates estimated nominal burst pressure for other temperatures.



Continental Disc Corporation has representatives located throughout the world. Contact the Continental Disc Corporation office nearest you for the authorized representative in your area or visit www.contdisc.com.

CORPORATE HEADQUARTERS

Continental Disc Corporation
3160 W. Heartland Drive
Liberty, MO 64068-3385 USA

Phone: (816) 792-1500
FAX: (816) 792-2277/5447
E-mail: pressure@contdisc.com
Website: www.contdisc.com

THE NETHERLANDS

Continental Disc Corporation
Energieweg 20
2382 NJ Zoeterwoude-Rijndijk
The Netherlands

Phone: + (31) 71-5412221
FAX: + (31) 71-5414361
E-mail: cdcnl@contdisc.com

CHINA

Continental Disc Corporation
Room 910, Tower B, COFCO Plaza
No. 8 JianGuoMenNei Avenue
Beijing (100005)
P.R. China

Phone: + (86) 10-6522-4885
Fax: + (86) 10-6522-2885
Mobile: + (86) 137-0103-8871
E-mail: cdcchina@contdisc.com

DUBAI

Continental Disc Corporation
P.O. Box 2234
Dubai, U.A.E.

Phone: + (971) 43214490
FAX: + (971) 43438840
Mobile: + (971) 508129525
E-mail: cdcme@contdisc.com