



Preparation and Installation of the Composite Type Rupture Disc (Light Lip and Heavy Lip) in 30° Seat Insert, Full-Bolted, and Union Type Holder

WARNING

USER SHOULD READ AND THOROUGHLY UNDERSTAND THESE INSTRUCTIONS BEFORE INSTALLING RUPTURE DISC. THESE INSTRUCTIONS DO NOT PURPORT TO ADDRESS ALL OF THE SAFETY FACTORS ASSOCIATED WITH THE RUPTURE DISC'S USE IN SERVICE. IT IS THE RESPONSIBILITY OF THE USER TO ESTABLISH APPROPRIATE SAFETY, HEALTH, AND TRAINING MEASURES FOR THEIR PERSONNEL INSTALLING, SERVICING, OR WORKING IN AN AREA WHERE RUPTURE DISC ASSEMBLIES ARE IN USE. SERVICE AND/OR MAINTENANCE ON OR AROUND THE RUPTURE DISC DEVICE MUST NOT BE PERFORMED WHILE THE DEVICE IS SUBJECTED TO OPERATING PRESSURES AND/OR TEMPERATURES.

IT IS THE USER'S SOLE RESPONSIBILITY FOR DESIGN AND PLACEMENT OF RUPTURE DISCS WITHIN THEIR FACILITY AND UPON THE EQUIPMENT UPON WHICH THE RUPTURE DISC OF USER'S SELECTION IS TO BE LOCATED. IT IS USER'S SOLE RESPONSIBILITY FOR THE DESIGN OF ADEQUATE VENTING AND INSTALLATION OF ADEQUATE VENT PIPING OR DIRECTIONAL FLOW AFTER RUPTURE OCCURS WITH THE RUPTURE DISC AS INTENDED. WHEN SIZE IS SPECIFIED, CONTINENTAL DISC CORPORATION ASSUMES THAT ADEQUATE PROVISIONS HAVE BEEN MADE BY PURCHASER FOR PROPER VENTING OF A SYSTEM TO RELIEVE THE SPECIFIC PRESSURE. LOCATE RUPTURE DISC WHERE PEOPLE OR PROPERTY WILL NOT BE EXPOSED TO THE SYSTEM DISCHARGE IN CASE OF RUPTURE. VENT TOXIC OR FLAMMABLE FUMES OR LIQUIDS TO A SAFE LOCATION TO PREVENT PERSONAL INJURY OR PROPERTY DAMAGE.

IT IS THE USER'S SOLE RESPONSIBILITY TO SPECIFY THE BURST PRESSURE RATING OF A RUPTURE DISC AT A COINCIDENT TEMPERATURE AT WHICH THE RUPTURE DISC IS TO BE USED. A RUPTURE DISC IS A TEMPERATURE SENSITIVE DEVICE. THE BURST PRESSURE OF THE RUPTURE DISC IS DIRECTLY AFFECTED BY ITS EXPOSURE TO THE COINCIDENT TEMPERATURE. GENERALLY, AS THE TEMPERATURE AT THE RUPTURE DISC INCREASES, THE BURST PRESSURE DECREASES; INVERSELY, AS THE TEMPERATURE AT THE RUPTURE DISC DECREASES, THE BURST PRESSURE MAY INCREASE. FAILURE TO PROPERLY UTILIZE A RUPTURE DISC AT THE SPECIFIED COINCIDENT TEMPERATURE COULD CAUSE PREMATURE FAILURE OR OVERPRESSURIZATION OF A SYSTEM.

THE INSTANTANEOUS RELEASE OF PRESSURE FROM THE RUPTURE DISC CAN CREATE VIOLENT NOISES DUE TO THE DISCHARGE AT SONIC VELOCITY. IT IS THE USER'S SOLE RESPONSIBILITY TO PROTECT AGAINST HEARING DAMAGE TO ANY BYSTANDERS.

RUPTURE DISCS AND TAGS ARE MADE OF METAL FOILS OF VARYING THICKNESS. THE METAL EDGES MAY BE SHARP. PERSONNEL INSTALLING OR EXAMINING THE RUPTURE DISCS SHOULD PROTECT AGAINST CUTS OR INJURY WHEN HANDLING THE RUPTURE DISC. DO NOT LIFT A RUPTURE DISC BY ITS ATTACHED TAG.

PARTICLES MAY BE DISCHARGED WHEN THE RUPTURE DISC RUPTURES. THESE PARTICLES MAY BE PART OF THE RUPTURE DISC ITSELF, OR OTHER ENVIRONMENTAL MATTER IN THE SYSTEM. IT IS THE USER'S SOLE RESPONSIBILITY TO ASSURE THAT THESE PARTICLES ARE DIRECTED TO A SAFE AREA TO PREVENT PERSONAL INJURY OR PROPERTY DAMAGE.

THERE IS NO GUARANTEE OF RUPTURE DISC LIFE. SUCH LIFE SPAN IS AFFECTED BY CORROSION, CREEP AND FATIGUE, AND PHYSICAL DAMAGE. THESE CONDITIONS WILL DERATE THE RUPTURE DISC TO A LOWER SET PRESSURE. THE CUSTOMER AND/OR USER SHOULD BE PREPARED TO HANDLE PREMATURE FAILURE OF THE RUPTURE DISC. THE MEDIA OR OTHER ENVIRONMENTAL CONDITIONS SHOULD NOT ALLOW ANY BUILDUP OR SOLIDIFICATION OF MEDIA TO OCCUR ON A RUPTURE DISC. THIS MAY INCREASE THE PRESSURE SETTING OF THE RUPTURE DISC.

CUSTOMER AND/OR ITS INSTALLER SHALL BE SOLELY RESPONSIBLE FOR THE PROPER INSTALLATION OF SELLER'S HOLDERS AND RUPTURE DISCS INTO A SYSTEM. CUSTOMER AND/OR ITS INSTALLER SHALL BE SOLELY RESPONSIBLE FOR IMPROPER INSTALLATION AND PHYSICAL DAMAGE RESULTING THEREFROM, INCLUDING BUT NOT LIMITED TO, DAMAGE RESULTING FROM LEAKAGE, IMPROPER TORQUING OR SEATING OF A RUPTURE DISC OR FAILURE TO FOLLOW INSTALLATION INSTRUCTIONS WHERE PROVIDED.

RUPTURE DISCS ARE PRECISION SAFETY DEVICES AND MUST BE INSTALLED PROPERLY. RUPTURE DISCS MUST BE INSTALLED BY TRAINED, KNOWLEDGEABLE INSTALLERS AND ONLY WITHIN ENVIRONMENTS SUITABLE AND APPROPRIATE FOR A RUPTURE DISC. CARE MUST BE USED IN A FACILITY'S DESIGN TO PROTECT BOTH THE RUPTURE DISC FROM INADVERTENT DAMAGE WHICH COULD CAUSE ITS PREMATURE RELEASE AND TO PROTECT INDIVIDUALS EXPOSED TO HAZARDS CREATED BY SUCH SUDDEN RELEASE.

PROPER INSTALLATION OF A RUPTURE DISC IS CRITICAL TO PERFORMANCE AND TO SAFETY. FAILURE TO PROVIDE PROPER SEATING OF A RUPTURE DISC MAY AFFECT RUPTURE DISC PERFORMANCE, BURST PRESSURE ACCURACY AND MAY RESULT IN ITS PREMATURE FAILURE.

I. Safety Precautions Before Installation

1. The Composite Type rupture disc is a precision instrument and must be handled with extreme care. Rupture discs should be installed only by qualified personnel familiar with rupture discs and proper piping practices.
2. Do not install rupture disc if there is any damage in the dome area. A damaged rupture disc is any rupture disc with visible nicks or dents in the dome.
3. Continental Disc Corporation does not recommend reinstalling a rupture disc that has been removed from the holder as reinstallation may adversely affect the joint sealing capabilities and/or performance of the rupture disc.
4. See rupture disc tag to verify set pressure, operating temperature, and all other operating parameters.

II. Insert Type 30° Seat Holder

A. Preparation of Holders for Installation

New Installation

Clean all foreign material from the rupture disc sealing area of both the holder inlet and outlet.

Replacement Installation

1. Remove the holder from the system and place on a flat surface.
2. Disassemble the holder by loosening the pre-assembly screws, or by removing the pre-assembly cap screws, whichever is applicable. Lift the holder outlet up and set aside; then remove the burst rupture disc.
3. Clean the rupture disc sealing area of both the holder inlet and outlet. These surfaces must be completely clean and free of all rust, corrosion, and foreign material to ensure a proper seal. Use of solvents, steel wool, or fine emery cloth is permissible. Do not re-machine. Do not use scraper or abrasives.
4. Inspect the rupture disc sealing area for nicks, scratches, or pitting. If any of these conditions are present, consult the factory for repair.
5. Remove any adhered gasket material from previous installation.

B. Assembly of the Rupture Disc and Holder (See Figure A)

Component parts of the Insert Type 30° Seat Holder assembly are illustrated in the proper installation sequence.

1. Carefully remove and discard any shipping protectors furnished with rupture discs or holder. **DO NOT INSTALL A SHIPPING PROTECTOR IN A HOLDER ASSEMBLY.**
2. Place the holder inlet on a flat surface.
3. Place the COMPOSITE Type rupture disc on the holder inlet opening with the dome side facing up as illustrated.
4. Align and lower the holder outlet carefully onto the holder inlet.
5. Fasten the assembly together by tightening the pre-assembly screws or by replacing and tightening the pre-assembly cap screws.

C. Installation of the Insert Type 30° Seat Holder Assembly Into the System (See Figure B)

1. Before placing the assembly into the system, ensure that the companion flange gasket surfaces are clean and free of all rust, corrosion, and foreign material.
2. A J-Hook (optional) may be provided in the holder inlet to ensure correct installation of the assembly relative to flow direction. If the J-Hook is used, the corresponding inlet companion flange must be drilled to accommodate the J-Hook prior to installation of the assembly. Refer to the J-Hook Installation Guide for locating and drilling specifications. NOTE: If replacing another Preventative Maintenance manufacturer's holder, the corresponding inlet companion flange

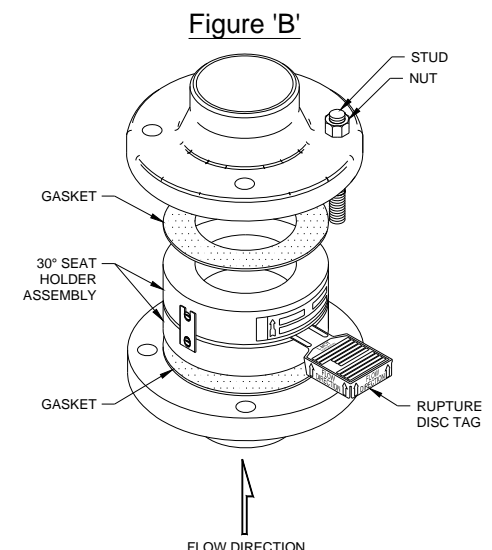
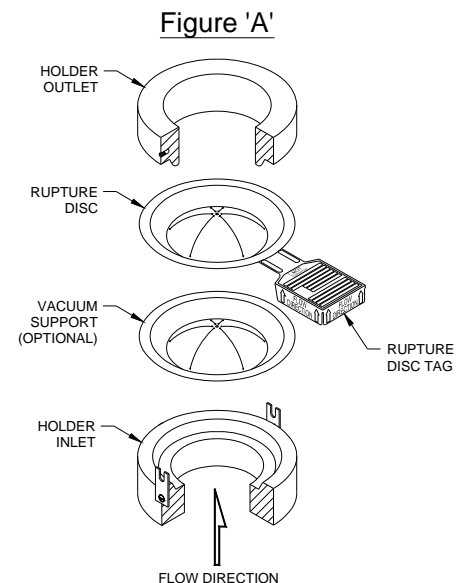

must be re-drilled to accommodate the J-hook in the LAMOT holder inlet.

3. Install the Insert Type 30° Seat Holder assembly and customer furnished gaskets, **WITH ALL FLOW ARROWS POINTING IN THE PROPER FLOW DIRECTION**, and the J-Hook (if furnished) inserted into the drilled companion flange.
4. Install lightly oiled, free running studs and nuts to finger tightness. Using a cross torquing pattern (see Figure C), torque each nut with a calibrated torque wrench at 20% increments of recommended torque value (see Table 1). Repeat 20% increments and cross torquing pattern until final torque value is achieved. Recheck all nuts in rotational sequence at final torque value. When properly torqued, the distance between the holder inlet and the holder outlet should be approximately equal around the perimeter of the holder. These values are based on using gasket materials having a gasket factor of 2.75, gasket seating stress of 3,700 psi, and stud and nut material per ASME SA193-B7 and SA194-2H respectively, with a stress of up to 25,000 psi. The use of studs and nuts with lower strength may prove unsatisfactory.

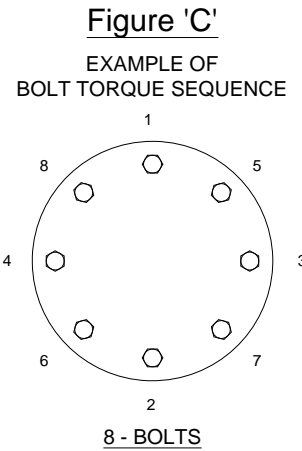

III. Full-Bolted Type 30° Seat Holder

A. Preparation of Holders for Installation

New Installation

Clean all foreign material from the rupture disc sealing area of both the holder inlet and outlet.

Replacement Installation

1. Remove the studs and nuts that hold the assembly together.
2. Separate the inlet and outlet; then remove the burst rupture disc.
3. Clean the rupture disc sealing area of both the holder inlet and outlet. These surfaces must be completely clean and free of all rust, corrosion, and foreign material to ensure a proper seal. Use of solvents, steel wool, or fine emery cloth is permissible. Do not re-machine. Do not use scraper or abrasives.
4. Inspect the rupture disc sealing area for nicks, scratches, or pitting. If any of these conditions are present, consult the factory for repair.
5. Remove any adhered gasket material from previous installation.

B. Assembly of the Rupture Disc and Holder (See Figure D)

Component parts of the Full-Bolted Type 30° Seat Holder assembly are illustrated in the proper installation sequence.

1. Carefully remove and discard any shipping protectors furnished with rupture discs or holder. **DO NOT INSTALL A SHIPPING PROTECTOR IN A HOLDER ASSEMBLY.**
2. Place the COMPOSITE Type rupture disc on the holder inlet opening with the dome side facing up as illustrated.
3. Align and lower the holder outlet carefully onto the holder inlet.
4. Install lightly oiled, free running studs and nuts to finger tightness. Using a cross torquing pattern (see Figure C), torque each nut with a calibrated torque wrench at 20% increments of recommended torque value (see Table 1). Repeat 20% increments and cross torquing pattern until final torque value is achieved. Recheck all nuts in rotational sequence at final torque value. When properly torqued, the distance between the holder inlet and the holder outlet should be approximately equal around the perimeter of the holder. These values are based on using gasket materials having a gasket factor of 2.75, gasket seating stress of 3,700 psi, and stud and nut material per ASME SA193-B7 and SA194-2H respectively, with a stress of up to 25,000 psi. The use of studs and nuts with lower strength may prove unsatisfactory.

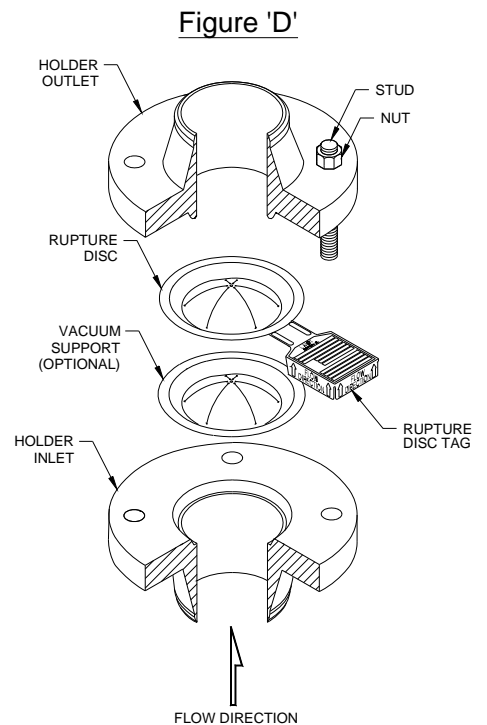

IV. Union Type Holder

A. Preparation of Holders for Installation

New and Replacement Installation

1. Clean the rupture disc sealing area of both the holder inlet and outlet. These surfaces must be completely clean and free of all rust, corrosion, and foreign material to ensure a proper seal. Use of solvents, steel wool, or fine emery cloth is permissible. Do not re-machine. Do not use scraper or abrasives.
2. Care should be taken during assembly and installation to ensure that nothing sharp protrudes down through the inlet or outlet cavities. A rupture disc that has been scratched, dented, or damaged in any way, may result in premature failure.

B. Assembly of the Rupture Disc and Holder (See Figure E)

Component parts of the Union Type assembly are illustrated in the proper installation sequence.

1. Carefully remove and discard any shipping protectors furnished with rupture discs or holder. **DO NOT INSTALL A SHIPPING PROTECTOR IN A HOLDER ASSEMBLY.**
2. Place the holder inlet on a flat surface.
3. Position the rupture disc in the holder inlet with the dome side facing up as shown. Handle with care.
4. Carefully lower the holder outlet onto the rupture disc.
5. Slip the nut over the holder outlet and thread it onto the holder inlet. Place a wrench on the holder inlet to keep it from turning. Using a calibrated torque wrench, torque the nut to the following requirements:

Size	Torque for Discs w/Teflon Seals		
	Pressure Rating	Torque Requirement	
	Holder	(Ft•Lbs)	(N•m)
1/2"	3000	50	68
	6000	80	108
1"	2000	150	203
	4000	150	203
	6000	150	203
1-1/2"	2000	200	271
	4000	200	271
2"	2000	350	475
	4000	350	475

Size	Torque for Discs w/Metal Seals		
	Pressure Rating	Torque Requirement	
	Holder	(Ft•Lbs)	(N•m)
1/2"	3000	50	68
	6000	80	108
1"	2000	150	203
	4000	200	271
	6000	300	407
1-1/2"	2000	400	542
	4000	800	1085
2"	2000	1500	2034
	4000	2000	2711

Figure 'E'

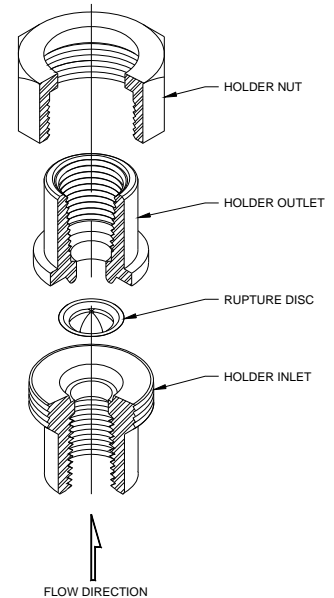
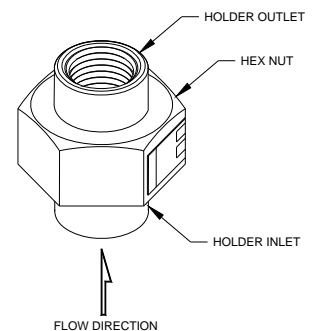

Figure 'F'



C. Installation of the Union Type Assembly into the System (See Figure F)

1. Assure that the unit being installed is compatible with current system operating conditions.
2. Before installing the Union Type assembly into the system, clean mating threads of all grit, dirt, or foreign material to ensure proper seal.
3. Install the Union Type Assembly **WITH ALL FLOW ARROWS POINTING IN THE PROPER FLOW DIRECTION.**
4. When installing the assembly into the system, do not tighten or loosen seal between holder inlet and holder outlet, for this could cause damage to the rupture disc or cause premature failure.

V. Preventative Maintenance

1. Risk assessment and an annual rupture disc replacement are recommended. Rupture disc service life is determined by system operating conditions. The effects of severe pressure/vacuum cycles, corrosion, temperature variations, or other adverse conditions must be evaluated by the user through actual service experience to determine optimal service life.
2. **IF THE RUPTURE DISC IS NOT REPLACED PERIODICALLY WHEN EXPOSED TO THESE CONDITIONS, PREMATURE FAILURE OF THE RUPTURE DISC MAY OCCUR, THEREBY DISCHARGING THE PROCESS MEDIA.**
3. To avoid extended downtime, maintain three spare rupture discs in stock at all times for each holder in use. The number of spares required ultimately will be determined by service conditions.

VI. Customer Service

If you wish to discuss your application, installation, or maintenance, please contact the Customer Service Department at one of the addresses shown on the last page of these instructions.

Recommended Torque Values for Composite Type Rupture Discs
(Light Lip and Heavy Lip)

TABLE 1

SIZE		COMPANION FLANGES			RUPTURE DISCS WITH TEFLON SEALS		RUPTURE DISCS WITH METAL SEALS	
IN.	MM	ANSI	DIN	JIS	TORQUE (FT•LB)	TORQUE (N•m)	TORQUE (FT•LB)	TORQUE (N•m)
1	25	150	---	---	9	12	14	19
1	25	---	10/16	---	9	12	13	18
1	25	---	---	10/16/20	12	16	18	24
1	25	300/600	---	30/40	12	16	20	28
1	25	---	25/40	---	9	12	15	20
1	25	900/1500	---	---	15	20	30	40
1	25	2500	---	---	15	20	30	40
1½	40	150	---	---	13	18	20	28
1½	40	---	10/16	10/16/20	17	23	26	36
1½	40	300/600	---	---	20	27	50	68
1½	40	---	25/40	---	17	23	42	56
1½	40	---	---	30/40	21	28	52	70
1½	40	900/1500	---	---	30	41	60	82
1½	40	2500	---	---	35	47	70	94
2	50	150	10/16	10	21	28	30	40
2	50	---	---	16/20	11	15	15	20
2	50	300/600	---	30/40	39	53	30	40
2	50	---	25/40	---	79	107	60	82
2	50	900/1500	---	---	20	27	40	54
3	80	150	---	---	20	27	30	40
3	80	---	10/16	10	10	14	20	28
3	80	---	---	16/20	13	18	26	36
3	80	300/600	---	---	20	27	40	54
3	80	---	25/40	---	17	23	34	46
3	80	---	---	30/40	21	28	42	56
4	100	150	10/16	10	15	20	30	40
4	100	---	---	16/20	19	26	38	52
4	100	300	---	--	25	34	50	68
4	100	---	25/40	---	26	35	52	70
4	100	---	---	30	29	39	58	78
4	100	600	---	40	30	41	60	82

Recommended Torque Values for Composite Type Rupture Discs
(Light Lip and Heavy Lip)

TABLE 1

SIZE		COMPANION FLANGES			RUPTURE DISCS WITH TEFLON SEALS		RUPTURE DISCS WITH METAL SEALS	
IN.	MM	ANSI	DIN	JIS	TORQUE (FT•LB)	TORQUE (N•m)	TORQUE (FT•LB)	TORQUE (N•m)
6	150	150	---	---	20	27	40	54
6	150	---	10/16	10	21	28	42	56
6	150	---	---	16/20	15	20	30	40
6	150	300	---	---	20	27	40	54
6	150	---	25/40	---	38	52	76	104
6	150	---	---	30	25	34	50	68
8	200	150	---	---	50	68	100	136
8	200	---	10	---	52	70	104	140
8	200	---	16	10	35	47	70	94
8	200	---	---	16/20	38	52	76	104
8	200	300	---	---	40	54	80	108
8	200	---	25/40	30	43	58	86	116
10	250	150	---	---	60	81	120	162
10	250	---	10	---	54	73	108	146
10	250	---	---	10	59	80	118	160
10	250	---	16	16/20	65	88	130	176
10	250	300	---	---	50	68	100	136
10	250	---	25	---	71	96	142	192
10	250	---	40	30	79	107	158	214
12	300	150	---	---	90	122	180	244
12	300	---	10	---	81	110	162	220
12	300	---	---	10	67	91	134	182
12	300	---	16	---	97	132	194	264
12	300	---	---	16/20	73	99	146	198
12	300	300	---	---	90	122	180	244

LAMOT®

A Division of
Continental Disc Corporation



First Certified in 1992



ASME Code Symbol Stamp
If stamped, this product is built in accordance with the requirements of the ASME Boiler and Pressure Vessel Code, Section VIII, Division 1.

China Manufacture License
Products are in full compliance with the provisions of the Peoples Republic of China Import Regulations for Boiler and Pressure Vessel safety devices.



3A Sanitary Standards Stamp
If stamped, this product is in full compliance with the 3A standards, Serial #60-00, of the International Association of Milk, Food, and Environmental Sanitarians, Inc.



European Union CE Mark
If stamped, this product is certified to conform to the essential requirements of the Pressure Equipment Directive.

Continental Disc Corporation has representatives located throughout the world.
Contact the C.D.C. office nearest you for the authorized representative in your area.

CORPORATE HEADQUARTERS

Continental Disc Corporation

3160 W. Heartland Drive
Liberty, Missouri 64068-3385 USA
Phone: (816) 792-1500
FAX: (816) 792-2277 / 5447
E-mail: pressure@contdisc.com
Website: www.contdisc.com

THE NETHERLANDS

Continental Disc Corporation
Energieweg 20
2382 NJ Zoeterwoude-Rijndijk
The Netherlands
Phone: +(31) 71-5412221
FAX: +(31) 71-5414361
E-mail: cdcnl@contdisc.com

CHINA

Continental Disc Corporation
Room 910, Tower B, COFCO Plaza
No. 8 JianGuoMenNei Avenue
Beijing (100005)
P.R. China
Phone: +(86) 10 6522 4885
Fax: +(86) 10 6522 2885
Mobile: +(86) 137 0103 8871
E-mail: cdcchina@contdisc.com

DUBAI

Continental Disc Corporation
P. O. Box 2234
Dubai, U.A.E.
Phone: +(971) 4 280 9023
Fax: +(971) 4 280 9028
Mobile: +(971) 508129525
E-mail: cdcme@contdisc.com

Continental Disc Corporation reserves the right to alter the information in this publication without notice.

Reproduction without written permission prohibited.

©1994, 1995, 1997, 1998, 2002, 2003, 2005, 2008, 2009, 2010
Continental Disc Corporation

Printed in U.S.A.