



## Preparation and Installation of the Screw Type Holder Assembly

### WARNING

USER SHOULD READ AND THOROUGHLY UNDERSTAND THESE INSTRUCTIONS BEFORE INSTALLING RUPTURE DISC. THESE INSTRUCTIONS DO NOT PURPORT TO ADDRESS ALL OF THE SAFETY FACTORS ASSOCIATED WITH THE RUPTURE DISC'S USE IN SERVICE. IT IS THE RESPONSIBILITY OF THE USER TO ESTABLISH APPROPRIATE SAFETY, HEALTH, AND TRAINING MEASURES FOR THEIR PERSONNEL INSTALLING, SERVICING, OR WORKING IN AN AREA WHERE RUPTURE DISC ASSEMBLIES ARE IN USE. SERVICE AND/OR MAINTENANCE ON OR AROUND THE RUPTURE DISC DEVICE MUST NOT BE PERFORMED WHILE THE DEVICE IS SUBJECTED TO OPERATING PRESSURES AND/OR TEMPERATURES.

IT IS THE USER'S SOLE RESPONSIBILITY FOR DESIGN AND PLACEMENT OF RUPTURE DISCS WITHIN THEIR FACILITY AND UPON THE EQUIPMENT UPON WHICH THE RUPTURE DISC OF USER'S SELECTION IS TO BE LOCATED. IT IS USER'S SOLE RESPONSIBILITY FOR THE DESIGN OF ADEQUATE VENTING AND INSTALLATION OF ADEQUATE VENT PIPING OR DIRECTIONAL FLOW AFTER RUPTURE OCCURS WITH THE RUPTURE DISC AS INTENDED. WHEN SIZE IS SPECIFIED, CONTINENTAL DISC CORPORATION ASSUMES THAT ADEQUATE PROVISIONS HAVE BEEN MADE BY PURCHASER FOR PROPER VENTING OF A SYSTEM TO RELIEVE THE SPECIFIC PRESSURE. LOCATE RUPTURE DISC WHERE PEOPLE OR PROPERTY WILL NOT BE EXPOSED TO THE SYSTEM DISCHARGE IN CASE OF RUPTURE. VENT TOXIC OR FLAMMABLE FUMES OR LIQUIDS TO A SAFE LOCATION TO PREVENT PERSONAL INJURY OR PROPERTY DAMAGE.

IT IS THE USER'S SOLE RESPONSIBILITY TO SPECIFY THE BURST PRESSURE RATING OF A RUPTURE DISC AT A COINCIDENT TEMPERATURE AT WHICH THE RUPTURE DISC IS TO BE USED. A RUPTURE DISC IS A TEMPERATURE SENSITIVE DEVICE. THE BURST PRESSURE OF THE RUPTURE DISC IS DIRECTLY AFFECTED BY ITS EXPOSURE TO THE COINCIDENT TEMPERATURE. GENERALLY, AS THE TEMPERATURE AT THE RUPTURE DISC INCREASES, THE BURST PRESSURE DECREASES; INVERSELY, AS THE TEMPERATURE AT THE RUPTURE DISC DECREASES, THE BURST PRESSURE MAY INCREASE. FAILURE TO PROPERLY UTILIZE A RUPTURE DISC AT THE SPECIFIED COINCIDENT TEMPERATURE COULD CAUSE PREMATURE FAILURE OR OVERPRESSURIZATION OF A SYSTEM.

THE INSTANTANEOUS RELEASE OF PRESSURE FROM THE RUPTURE DISC CAN CREATE VIOLENT NOISES DUE TO THE DISCHARGE AT SONIC VELOCITY. IT IS THE USER'S SOLE RESPONSIBILITY TO PROTECT AGAINST HEARING DAMAGE TO ANY BYSTANDERS.

RUPTURE DISCS AND TAGS ARE MADE OF METAL FOILS OF VARYING THICKNESS. THE METAL EDGES MAY BE SHARP. PERSONNEL INSTALLING OR EXAMINING THE RUPTURE DISCS SHOULD PROTECT AGAINST CUTS OR INJURY WHEN HANDLING THE RUPTURE DISC. DO NOT LIFT A RUPTURE DISC BY ITS ATTACHED TAG.

PARTICLES MAY BE DISCHARGED WHEN THE RUPTURE DISC RUPTURES. THESE PARTICLES MAY BE PART OF THE RUPTURE DISC ITSELF, OR OTHER ENVIRONMENTAL MATTER IN THE SYSTEM. IT IS THE USER'S SOLE RESPONSIBILITY TO ASSURE THAT THESE PARTICLES ARE DIRECTED TO A SAFE AREA TO PREVENT PERSONAL INJURY OR PROPERTY DAMAGE.

THERE IS NO GUARANTEE OF RUPTURE DISC LIFE. SUCH LIFE SPAN IS AFFECTED BY CORROSION, CREEP AND FATIGUE, AND PHYSICAL DAMAGE. THESE CONDITIONS WILL DERATE THE RUPTURE DISC TO A LOWER SET PRESSURE. THE CUSTOMER AND/OR USER SHOULD BE PREPARED TO HANDLE PREMATURE FAILURE OF THE RUPTURE DISC. THE MEDIA OR OTHER ENVIRONMENTAL CONDITIONS SHOULD NOT ALLOW ANY BUILDUP OR SOLIDIFICATION OF MEDIA TO OCCUR ON A RUPTURE DISC. THIS MAY INCREASE THE PRESSURE SETTING OF THE RUPTURE DISC.

CUSTOMER AND/OR ITS INSTALLER SHALL BE SOLELY RESPONSIBLE FOR THE PROPER INSTALLATION OF SELLER'S HOLDERS AND RUPTURE DISCS INTO A SYSTEM. CUSTOMER AND/OR ITS INSTALLER SHALL BE SOLELY RESPONSIBLE FOR IMPROPER INSTALLATION AND PHYSICAL DAMAGE RESULTING THEREFROM, INCLUDING BUT NOT LIMITED TO, DAMAGE RESULTING FROM LEAKAGE, IMPROPER TORQUING OR SEATING OF A RUPTURE DISC OR FAILURE TO FOLLOW INSTALLATION INSTRUCTIONS WHERE PROVIDED.

RUPTURE DISCS ARE PRECISION SAFETY DEVICES AND MUST BE INSTALLED PROPERLY. RUPTURE DISCS MUST BE INSTALLED BY TRAINED, KNOWLEDGEABLE INSTALLERS AND ONLY WITHIN ENVIRONMENTS SUITABLE AND APPROPRIATE FOR A RUPTURE DISC. CARE MUST BE USED IN A FACILITY'S DESIGN TO PROTECT BOTH THE RUPTURE DISC FROM INADVERTENT DAMAGE WHICH COULD CAUSE ITS PREMATURE RELEASE AND TO PROTECT INDIVIDUALS EXPOSED TO HAZARDS CREATED BY SUCH SUDDEN RELEASE.

PROPER INSTALLATION OF A RUPTURE DISC IS CRITICAL TO PERFORMANCE AND TO SAFETY. FAILURE TO PROVIDE PROPER SEATING OF A RUPTURE DISC MAY AFFECT RUPTURE DISC PERFORMANCE, BURST PRESSURE ACCURACY AND MAY RESULT IN ITS PREMATURE FAILURE.

## I. Safety Precautions Before Installation

1. The rupture disc is a precision instrument and must be handled with extreme care. Rupture discs should be installed only by qualified personnel familiar with rupture discs and proper piping practices.
2. Do not install rupture disc if there is any damage in the dome area. A damaged rupture disc is any rupture disc with visible nicks or dents in the dome.
3. Continental Disc Corporation does not recommend reinstalling a rupture disc that has been removed from the holder as reinstallation may adversely affect the joint sealing capabilities and/or performance of the rupture disc.
4. See rupture disc tag for set pressure at operating temperature.

## II. Preparation of Holders for Installation

### New Installation and Replacement Installation

1. If oxygen or LOX cleaning has been requested, do not remove SCREW TYPE assembly from sealed bag until ready for installation.
2. Clean the rupture disc sealing area of both the holder inlet and the holddown ring. These surfaces must be completely clean and free of all rust, corrosion, and foreign material to ensure a proper seal. Use of solvents, steel wool, or fine emery cloth is permissible. Do not re-machine. Do not use scraper or abrasives.
3. Inspect the rupture disc sealing area for nicks, scratches, or pitting. If any of these conditions are present, consult the factory for repair.

## III. Assembly of the Rupture Disc and Holder (See Figure A)

Component parts of the SCREW TYPE assembly are illustrated in the proper installation sequence.

**\*ALL ALUMINUM RUPTURE DISCS MUST HAVE TEFLON GASKETS ON TOP AND BOTTOM SIDE OF THE RUPTURE DISC TO PREVENT GALVANIC CORROSION BETWEEN THE ALUMINUM RUPTURE DISC AND BRASS PARTS.\***

1. Place the holder inlet on a flat surface.
2. Place the vacuum support (if applicable) and the rupture disc, dome side up, in the holder inlet opening as illustrated. Handle with care.
3. Carefully lower the holddown ring onto the rupture disc.
4. Fasten the assembly together by threading the holder outlet into the holder inlet, applying the following torque requirements:

	RATING (psig)	TORQUE Ft•Lbs / (N•m)	
		Aluminum	Other Material
1/2" STD Rupture Disc	0 - 1000	15/(20)	80/(108)
	1001 - 3000	60/(81)	100/(136)
	3001 - 15000	100/(135)	200/(271)
11/16" STD Rupture Disc	0 - 140	10/(14)	
	141 - 1000	15/(20)	35/(47)
	1001 - 2000	60/(81)	80/(108)
	2001 - 3000	60/(81)	120/(163)
11/16" LDV Rupture Disc	30 - 45		12.5/(17)
	46 - 130		17/(23)
	131 - 500		21/(28)
	501 - 1000		25/(34)

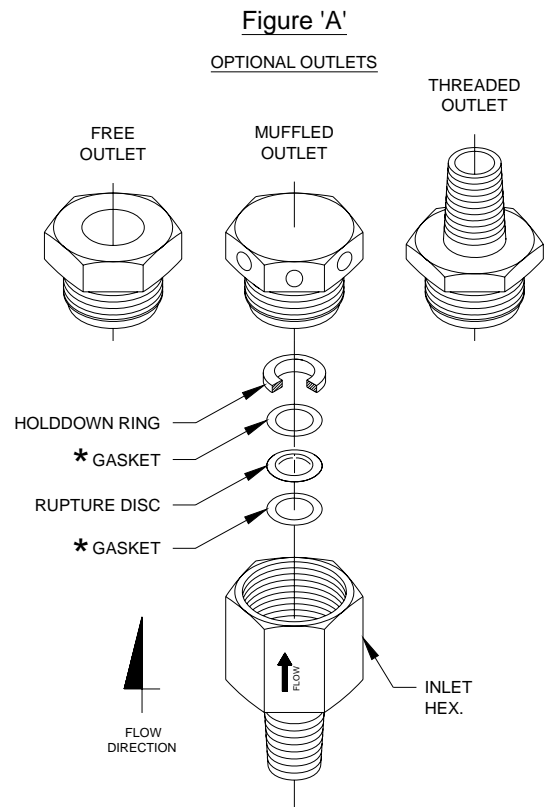

#### IV. Installation of the Screw Type Assembly Into the System (See Figure B)

1. Each SCREW TYPE assembly is permanently stamped with a maximum burst pressure rating. Prior to installation, verify that the unit chosen is compatible with current system operating conditions.
2. Before placing the SCREW TYPE assembly into the system, clean mating threads of all grit, dirt, or foreign material to ensure proper seal.
3. Installation of the assemblies:
  - a. Muffled Outlet and Free Outlet Assemblies: When installing the assembly, **DO NOT USE THE OUTLET HEX FOR TIGHTENING THE ASSEMBLY INTO THE SYSTEM, USE THE INLET HEX ONLY.** Do not tighten or loosen the seal between the inlet and outlet for this can cause damage to the rupture disc or cause premature failure.
  - b. Threaded Inlet and Outlet Assemblies:
    - 1) When installing the assembly, assure that the flow arrow, stamped on the inlet body, points in the proper system flow direction.
    - 2) **DO NOT USE THE OUTLET HEX FOR TIGHTENING ASSEMBLY INTO THE SYSTEM, USE THE INLET HEX ONLY.** Place a wrench on the outlet hex only to keep the outlet from turning while installing system outlet piping.

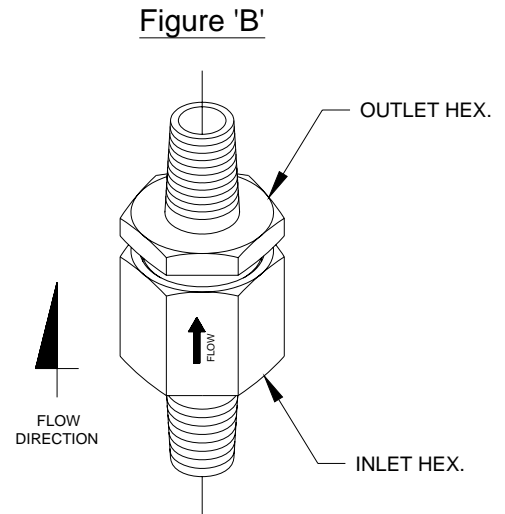

#### V. Preventative Maintenance

1. Risk assessment and an annual rupture disc replacement are recommended. Rupture disc service life is determined by system operating conditions. The effects of severe pressure/vacuum cycles, corrosion, temperature variations, or other adverse conditions must be evaluated by the user through actual service experience to determine optimal service life.
2. **IF THE RUPTURE DISC IS NOT REPLACED PERIODICALLY WHEN EXPOSED TO THESE CONDITIONS, PREMATURE FAILURE OF THE RUPTURE DISC MAY OCCUR, THEREBY DISCHARGING THE PROCESS MEDIA.**
3. To avoid extended downtime, maintain three spare rupture discs in stock at all times for each holder in use. The number of spares required ultimately will be determined by service conditions.

#### VI. Customer Service

If you wish to discuss your application, installation, or maintenance, please contact the Customer Service Department at one of the addresses shown below.

# LAMOT®

A Division of  
Continental Disc Corporation



First Certified in 1992



**ASME Code Symbol Stamp**  
If stamped, this product is built in accordance with the requirements of the ASME Boiler and Pressure Vessel Code, Section VIII, Division 1.

**China Manufacture License**  
Products are in full compliance with the provisions of the Peoples Republic of China Import Regulations for Boiler and Pressure Vessel safety devices.



**European Union CE Mark**  
If stamped, this product is certified to conform to the essential requirements of the Pressure Equipment Directive.

Continental Disc Corporation has representatives located throughout the world. Contact the C.D.C. office nearest you for the authorized representative in your area.

## LAMOT

13650 N. Promenade Blvd  
Stafford, Texas 77477 USA  
Phone: (281) 295-6900  
FAX: (281) 295-6950  
Website: [www.lamot.com](http://www.lamot.com)

## Continental Disc Corporation

3160 W. Heartland Drive  
Liberty, Missouri 64068-3385 USA  
Phone: (816) 792-1500  
FAX: (816) 792-2277 / 5447  
E-Mail: [pressure@contdisc.com](mailto:pressure@contdisc.com)  
Website: [www.contdisc.com](http://www.contdisc.com)

THE NETHERLANDS	UNITED KINGDOM	CHINA	DUBAI
Continental Disc Corporation Energieweg 20 2382 NJ Zoeterwoude-Rijndijk The Netherlands Phone: +(31) 71-5412221 Fax: +(31) 71-5414361 E-mail: <a href="mailto:cdcnl@contdisc.com">cdcnl@contdisc.com</a>	Continental Disc UK Ltd. Unit C, The Business Centre Faringdon Avenue, Harold Hill, Romford Essex RM3 8EN United Kingdom Phone: +(44) 1708-386444 Fax: +(44) 1708-386486 E-mail: <a href="mailto:cduk@contdisc.com">cduk@contdisc.com</a>	Continental Disc Corporation Room 910, Tower B, COFCO Plaza No. 8 JianGuoMenNei Avenue Beijing (100005) P.R. China Mobile: +(86) 137 0103 8871 E-mail: <a href="mailto:cdcchina@contdisc.com">cdcchina@contdisc.com</a>	Continental Disc Corporation P. O. Box 2234 Dubai, U.A.E. Phone: +(971) 43214490 Fax: +(971) 43438840 Mobile: +(971) 508129525 E-mail: <a href="mailto:cdme@contdisc.com">cdme@contdisc.com</a>

Continental Disc Corporation reserves the right to alter the information in this publication without notice.

Reproduction without written permission prohibited.

©1994, 2002, 2008, 2009 Continental Disc Corporation

Printed in U.S.A.