



**Continental Disc®
Corporation**

Installation and Maintenance of the Composite Type (CF) and Scored MICRO X® (CF) Rupture Disc and the CLEAN-SWEEP® Assembly

WARNING

USER SHOULD READ AND THOROUGHLY UNDERSTAND THESE INSTRUCTIONS BEFORE INSTALLING RUPTURE DISC. THESE INSTRUCTIONS DO NOT PURPORT TO ADDRESS ALL OF THE SAFETY FACTORS ASSOCIATED WITH THE RUPTURE DISC'S USE IN SERVICE. IT IS THE RESPONSIBILITY OF THE USER TO ESTABLISH APPROPRIATE SAFETY, HEALTH, AND TRAINING MEASURES FOR THEIR PERSONNEL INSTALLING, SERVICING, OR WORKING IN AN AREA WHERE RUPTURE DISC ASSEMBLIES ARE IN USE. SERVICE AND/OR MAINTENANCE ON OR AROUND THE RUPTURE DISC DEVICE MUST NOT BE PERFORMED WHILE THE DEVICE IS SUBJECTED TO OPERATING PRESSURES AND/OR TEMPERATURES.

IT IS THE USER'S SOLE RESPONSIBILITY FOR DESIGN AND PLACEMENT OF RUPTURE DISCS WITHIN THEIR FACILITY AND UPON THE EQUIPMENT UPON WHICH THE RUPTURE DISC OF USER'S SELECTION IS TO BE LOCATED. IT IS USER'S SOLE RESPONSIBILITY FOR THE DESIGN OF ADEQUATE VENTING AND INSTALLATION OF ADEQUATE VENT PIPING OR DIRECTIONAL FLOW AFTER RUPTURE OCCURS WITH THE RUPTURE DISC AS INTENDED. WHEN SIZE IS SPECIFIED, CONTINENTAL DISC CORPORATION ASSUMES THAT ADEQUATE PROVISIONS HAVE BEEN MADE BY PURCHASER FOR PROPER VENTING OF A SYSTEM TO RELIEVE THE SPECIFIC PRESSURE. LOCATE RUPTURE DISC WHERE PEOPLE OR PROPERTY WILL NOT BE EXPOSED TO THE SYSTEM DISCHARGE IN CASE OF RUPTURE. VENT TOXIC OR FLAMMABLE FUMES OR LIQUIDS TO A SAFE LOCATION TO PREVENT PERSONAL INJURY OR PROPERTY DAMAGE.

IT IS THE USER'S SOLE RESPONSIBILITY TO SPECIFY THE BURST PRESSURE RATING OF A RUPTURE DISC AT A COINCIDENT TEMPERATURE AT WHICH THE RUPTURE DISC IS TO BE USED. A RUPTURE DISC IS A TEMPERATURE SENSITIVE DEVICE. THE BURST PRESSURE OF THE RUPTURE DISC IS DIRECTLY AFFECTED BY ITS EXPOSURE TO THE COINCIDENT TEMPERATURE. GENERALLY, AS THE TEMPERATURE AT THE RUPTURE DISC INCREASES, THE BURST PRESSURE DECREASES; INVERSELY, AS THE TEMPERATURE AT THE RUPTURE DISC DECREASES, THE BURST PRESSURE MAY INCREASE. FAILURE TO PROPERLY UTILIZE A RUPTURE DISC AT THE SPECIFIED COINCIDENT TEMPERATURE COULD CAUSE PREMATURE FAILURE OR OVERPRESSURIZATION OF A SYSTEM.

THE INSTANTANEOUS RELEASE OF PRESSURE FROM THE RUPTURE DISC CAN CREATE VIOLENT NOISES DUE TO THE DISCHARGE AT SONIC VELOCITY. IT IS THE USER'S SOLE RESPONSIBILITY TO PROTECT AGAINST HEARING DAMAGE TO ANY BYSTANDERS.

RUPTURE DISCS AND TAGS ARE MADE OF METAL FOILS OF VARYING THICKNESS. THE METAL EDGES MAY BE SHARP. PERSONNEL INSTALLING OR EXAMINING THE RUPTURE DISCS SHOULD PROTECT AGAINST CUTS OR INJURY WHEN HANDLING THE RUPTURE DISC. DO NOT LIFT A RUPTURE DISC BY ITS ATTACHED TAG.

PARTICLES MAY BE DISCHARGED WHEN THE RUPTURE DISC RUPTURES. THESE PARTICLES MAY BE PART OF THE RUPTURE DISC ITSELF, OR OTHER ENVIRONMENTAL MATTER IN THE SYSTEM. IT IS THE USER'S SOLE RESPONSIBILITY TO ASSURE THAT THESE PARTICLES ARE DIRECTED TO A SAFE AREA TO PREVENT PERSONAL INJURY OR PROPERTY DAMAGE.

THERE IS NO GUARANTEE OF RUPTURE DISC LIFE. SUCH LIFE SPAN IS AFFECTED BY CORROSION, CREEP AND FATIGUE, AND PHYSICAL DAMAGE. THESE CONDITIONS WILL DERATE THE RUPTURE DISC TO A LOWER SET PRESSURE. THE CUSTOMER AND/OR USER SHOULD BE PREPARED TO HANDLE PREMATURE FAILURE OF THE RUPTURE DISC. THE MEDIA OR OTHER ENVIRONMENTAL CONDITIONS SHOULD NOT ALLOW ANY BUILDUP OR SOLIDIFICATION OF MEDIA TO OCCUR ON A RUPTURE DISC. THIS MAY INCREASE THE PRESSURE SETTING OF THE RUPTURE DISC.

CUSTOMER AND/OR ITS INSTALLER SHALL BE SOLELY RESPONSIBLE FOR THE PROPER INSTALLATION OF SELLER'S HOLDERS AND RUPTURE DISCS INTO A SYSTEM. CUSTOMER AND/OR ITS INSTALLER SHALL BE SOLELY RESPONSIBLE FOR IMPROPER INSTALLATION AND PHYSICAL DAMAGE RESULTING THEREFROM, INCLUDING BUT NOT LIMITED TO, DAMAGE RESULTING FROM LEAKAGE, IMPROPER TORQUING OR SEATING OF A RUPTURE DISC OR FAILURE TO FOLLOW INSTALLATION INSTRUCTIONS WHERE PROVIDED.

RUPTURE DISCS ARE PRECISION SAFETY DEVICES AND MUST BE INSTALLED PROPERLY. RUPTURE DISCS MUST BE INSTALLED BY TRAINED, KNOWLEDGEABLE INSTALLERS AND ONLY WITHIN ENVIRONMENTS SUITABLE AND APPROPRIATE FOR A RUPTURE DISC. CARE MUST BE USED IN A FACILITY'S DESIGN TO PROTECT BOTH THE RUPTURE DISC FROM INADVERTENT DAMAGE WHICH COULD CAUSE ITS PREMATURE RELEASE AND TO PROTECT INDIVIDUALS EXPOSED TO HAZARDS CREATED BY SUCH SUDDEN RELEASE.

PROPER INSTALLATION OF A RUPTURE DISC IS CRITICAL TO PERFORMANCE AND TO SAFETY. FAILURE TO PROVIDE PROPER SEATING OF A RUPTURE DISC MAY AFFECT RUPTURE DISC PERFORMANCE, BURST PRESSURE ACCURACY AND MAY RESULT IN ITS PREMATURE FAILURE.

A. INSTRUCTIONS FOR NEW INSTALLATION

I. CLEAN-SWEEP Body Installation (See Figure A)

1. Place the CLEAN-SWEEP assembly on a clean flat surface.
2. Disassemble the rupture disc holder portion by removing the nuts securing the companion flange to the body.
3. Lift the companion flange up and set aside.
4. Remove the spacer (if ordered), holder outlet, gaskets and shipping protector. **DO NOT INSTALL A SHIPPING PROTECTOR IN A CLEAN-SWEEP ASSEMBLY.**
5. Install the CLEAN-SWEEP body into the piping system using appropriate gasketing at both ends of the body.
6. Install and torque all studs and nuts using good piping practice, to a torque necessary to seal the gaskets.

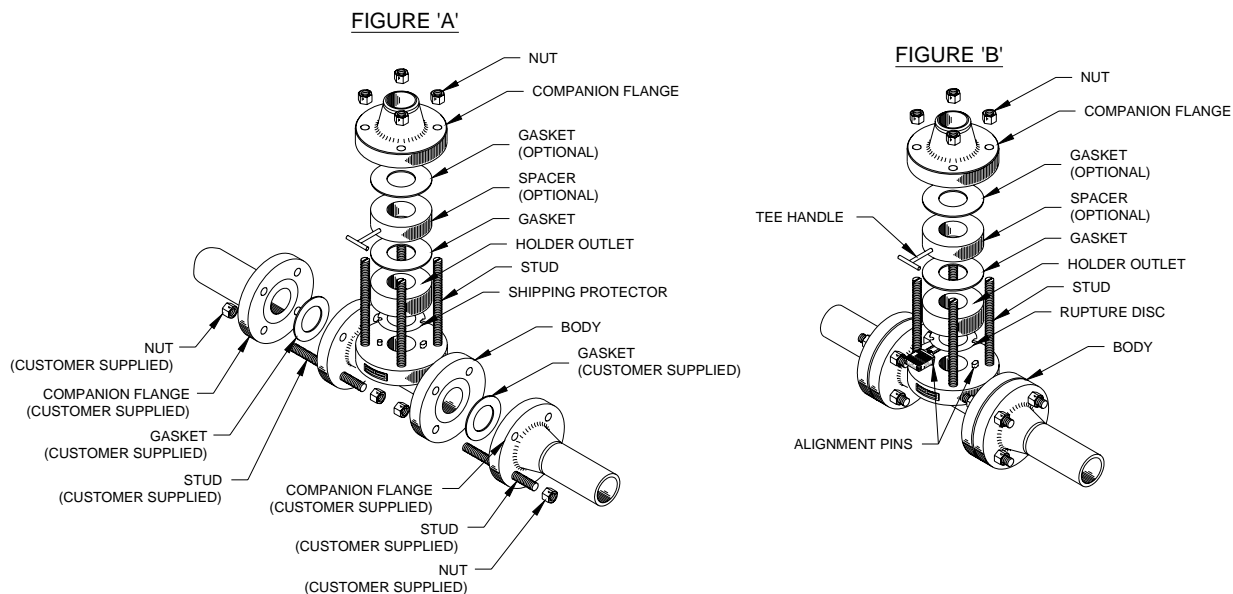

II. Assembly of the Rupture Disc and Holder (See Figure B)

1. **ENSURE THAT THE RUPTURE DISC DOES NOT EXCEED THE MAXIMUM DISC RATING STAMPED ON THE NAMEPLATE ATTACHED TO THE CLEAN-SWEEP BODY.** If this condition occurs, consult the factory.
2. Match the notches in the rupture disc with the shape of the pins in the body. Place the rupture disc over the pins with the dome side up.
3. Match the holes in the holder outlet with the shape of the pins in the body. Position the holder outlet carefully onto the body as shown, ensuring that the rupture disc is not damaged.
4. Place the gasket supplied on top of the holder outlet.
5. If the spacer was ordered, place it on top of the gasket then place the other gasket supplied on top of the spacer making sure the spacer and gaskets are concentric with the holder outlet.
6. Align the bolt holes in the companion flange with the studs in the body and lower the companion flange onto the gasket ensuring that everything remains concentric.
7. Install lightly oiled, free running studs and nuts to finder tightness. Using a cross torquing pattern (see Figure C) torque each nut with a calibrated torque wrench at 20% increments of recommended torque value (see Table 1). Repeat 20% increments and cross torquing pattern until final torque value is achieved. Recheck all nuts in rotational sequence at final torque value.

FIGURE 'C'
EXAMPLE OF
BOLT TORQUE SEQUENCE

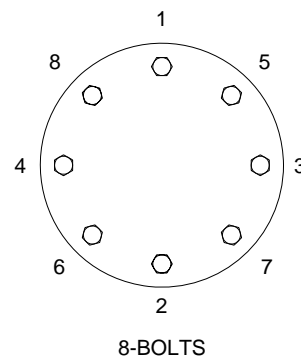

B. INSTRUCTIONS FOR REPLACEMENT RUPTURE DISC INSTALLATION

I. Safety Precautions Before Installation

1. The COMPOSITE TYPE and the Scored MICRO X rupture discs are precision instruments and must be handled with extreme care. Rupture discs should be installed only by qualified personnel familiar with rupture discs and proper piping practices.
2. Do not install rupture disc if there is any damage in the dome area. A damaged rupture disc is any rupture disc with visible nicks or dents in the dome.
3. Continental Disc Corporation does not recommend reinstalling a rupture disc that has been removed from the holder as reinstallation may adversely affect the joint sealing capabilities and/or performance of the rupture disc.

II. Preparation of the CLEAN-SWEEP Assembly for Installation

1. Disassemble the holder portion by removing the nuts securing the companion flange to the body.
2. Depending on the size of the body, use a screwdriver and remove enough of the studs securing the companion flange to the body to allow removal of the spacer (if ordered) and the holder outlet.
3. Remove the spacer (if ordered), holder outlet, and the burst rupture disc.
4. Clean the rupture disc sealing area of both the body and the holder outlet. These surfaces must be completely clean and free of all rust, corrosion, and foreign material to ensure a proper seal. Use of solvents, steel wool or fine emery cloth is permissible. Do not re-machine. Do not use scraper or abrasives.
5. Inspect the rupture disc sealing area for nicks, scratches or pitting. If any of these conditions are present, consult the factory for repair.

III. Assembly of the Rupture Disc and Holder (See Figure D)

1. **ENSURE THAT THE RUPTURE DISC DOES NOT EXCEED THE MAXIMUM DISC RATING STAMPED ON THE NAMEPLATE ATTACHED TO THE CLEAN-SWEEP BODY.** If this condition occurs, consult the factory.
2. Match the notches in the rupture disc with the shape of the pins in the body. Place the rupture disc over the pins with the dome side up.
3. Match the holes in the holder outlet with the shape of the pins in the body. Position the holder outlet carefully onto the body as shown, ensuring that the rupture disc is not damaged.
4. Place the gasket supplied on top of the holder outlet.
5. If the spacer was ordered, place it on top of the gasket then place the other gasket supplied on top of the spacer making sure the spacer and gaskets are concentric with the holder outlet.
6. Align the bolt holes in the companion flange with the studs in the body and lower the companion flange onto the gasket ensuring that everything remains concentric.
7. Install lightly oiled, free running studs and nuts to finder tightness. Using a cross torquing pattern (see Figure E) torque each nut with a calibrated torque wrench at 20% increments of recommended torque value (see Table 1). Repeat 20% increments and cross torquing pattern until final torque value is achieved. Recheck all nuts in rotational sequence at final torque value.

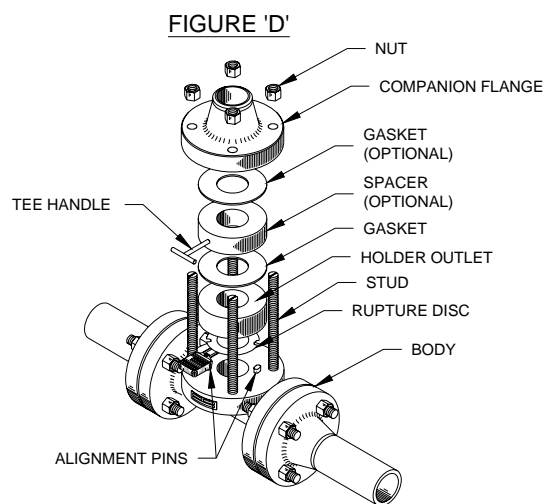
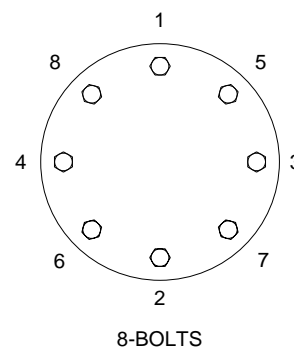

FIGURE 'E'
EXAMPLE OF
BOLT TORQUE SEQUENCE



C. MAINTENANCE INSTRUCTIONS

I. Preventative Maintenance

1. Risk assessment and an annual rupture disc replacement are recommended. Rupture disc service life is determined by system operating conditions. The effects of severe pressure/vacuum cycles, corrosion, temperature variations, or other adverse conditions must be evaluated by the user through actual service experience to determine optimal service life.
2. **IF THE RUPTURE DISC IS NOT REPLACED PERIODICALLY WHEN EXPOSED TO THESE CONDITIONS PREMATURE FAILURE OF THE RUPTURE DISC MAY OCCUR, THEREBY DISCHARGING THE PROCESS MEDIA.**
3. To avoid extended downtime, maintain three spare rupture discs in stock at all times for each holder in use. The number of spares required ultimately will be determined by service conditions.

D. CUSTOMER SERVICE

If you wish to discuss your application, installation, or maintenance, please contact the Customer Service Department at one of the addresses shown on the last page of these instructions.

COMPOSITE Type Rupture Disc incorporates U.S. Patent No.: 3,445,032.

Recommended Torque Values for Composite Flat Seat
and Scored MICRO X Rupture Discs
Sizes 1" Through 6"
TABLE 1

| SIZE | | COMPANION FLANGE RATING | | | RECOMMENDED TORQUE VALUE | |
|-------|-----|-------------------------|-------|----------|--------------------------|-----|
| IN | MM | ANSI | DIN | JIS | FT•LB | N•m |
| 1 | 25 | 150 | --- | --- | 35 | 47 |
| 1 | 25 | --- | 10/16 | --- | 33 | 45 |
| 1 | 25 | --- | --- | 10/16/20 | 44 | 60 |
| 1 | 25 | 300/600 | --- | --- | 65 | 88 |
| 1 | 25 | --- | 25/40 | --- | 49 | 66 |
| 1 | 25 | --- | --- | 30/40 | 66 | 89 |
| 1-1/2 | 40 | 150 | --- | --- | 35 | 47 |
| 1-1/2 | 40 | --- | 10/16 | 10/16/20 | 44 | 60 |
| 1-1/2 | 40 | 300/600 | --- | --- | 120 | 163 |
| 1-1/2 | 40 | --- | 25/40 | --- | 101 | 137 |
| 1-1/2 | 40 | --- | --- | 30/40 | 126 | 171 |
| 2 | 50 | 150 | --- | --- | 65 | 88 |
| 2 | 50 | --- | 10/16 | 10 | 66 | 89 |
| 2 | 50 | --- | --- | 16/20 | 33 | 45 |
| 2 | 50 | 300/600 | ----- | --- | 65 | 88 |
| 2 | 50 | --- | 25/40 | --- | 131 | 178 |
| 2 | 50 | --- | --- | 30/40 | 66 | 89 |
| 3 | 80 | 150 | --- | --- | 65 | 88 |
| 3 | 80 | --- | 10/16 | 10 | 33 | 45 |
| 3 | 80 | --- | --- | 16/20 | 41 | 56 |
| 3 | 80 | 300/600 | --- | --- | 120 | 163 |
| 3 | 80 | --- | 25/40 | --- | 101 | 137 |
| 3 | 80 | --- | --- | 30/40 | 126 | 171 |
| 4 | 100 | 150 | --- | --- | 65 | 88 |
| 4 | 100 | --- | 10/16 | 10 | 66 | 89 |
| 4 | 100 | --- | --- | 16/20 | 82 | 111 |
| 4 | 100 | 300 | --- | --- | 120 | 163 |
| 4 | 100 | --- | 25/40 | --- | 126 | 171 |
| 4 | 100 | --- | --- | 30 | 139 | 188 |
| 6 | 150 | 150 | --- | --- | 120 | 163 |
| 6 | 150 | --- | 10/16 | 10 | 126 | 171 |
| 6 | 150 | --- | --- | 16/20 | 92 | 125 |
| 6 | 150 | 300 | --- | --- | 120 | 163 |
| 6 | 150 | --- | 25/40 | --- | 227 | 308 |
| 6 | 150 | --- | --- | 30 | 151 | 205 |
| 6 | 150 | 600 | --- | --- | 275 | 373 |
| 6 | 150 | --- | --- | 40 | 260 | 352 |



**Continental Disc[®]
Corporation**

Performance Under Pressure[®]



Certified Quality System
First Certified In 1992



ASME Code Symbol Stamp
If stamped, this product is built in accordance with the requirements of the ASME Boiler and Pressure Vessel Code, Section VIII, Division 1.

China Manufacture License
Products are in full compliance with the provisions of the People's Republic of China Import Regulations for Boiler and Pressure Vessel safety devices.



3A Sanitary Standards Stamp
If stamped, this product is in full compliance with the 3A standards, Serial #60-00, of the International Association of Milk, Food, and Environmental Sanitarians, Inc.



European Union CE Mark Type Approval Stamp
If stamped, this product is certified to conform to the essential requirements of the Pressure Equipment Directive.

Continental Disc Corporation has representatives located throughout the world.
Contact the C.D.C. office nearest you for the authorized representative in your area.

CORPORATE HEADQUARTERS

Continental Disc Corporation

3160 W. Heartland Drive
Liberty, Missouri 64068-3385 USA
Phone: (816) 792-1500
FAX: (816) 792-2277 / 5447
E-mail: pressure@contdisc.com
Website: www.contdisc.com

THE NETHERLANDS

Continental Disc Corporation
Energieweg 20
2382 NJ Zoeterwoude-Rijndijk
The Netherlands
Phone: +(31) 71-5412221
FAX: +(31) 71-5414361
E-mail: cdcnl@contdisc.com

UNITED KINGDOM

Continental Disc UK Ltd.
Unit C, The Business Centre
Faringdon Avenue, Harold Hill
Romford, Essex RM3 8EN
United Kingdom
Phone: +(44) 1708-386444
FAX: +(44) 1708-386486
E-mail: cduk@contdisc.com

CHINA

Continental Disc Corporation
Room 910, Tower B, COFCO Plaza
No. 8 JianGuoMenNei Avenue
Beijing (100005)
P.R. China
Mobile: +(86) 137 0103 8871
E-mail: cdcchina@contdisc.com

DUBAI

Continental Disc Corporation
P. O. Box 2234
Dubai, U.A.E.
Phone: +(971) 43214490
Fax: +(971) 43438840
Mobile: +(971) 508129525
E-mail: kannan@contdisc.com