



**Continental Disc®
Corporation**

Installation and Maintenance of the Composite Type (QU) Rupture Disc and the Quick-Change® Housing and Cartridge Assembly

WARNING

USER SHOULD READ AND THOROUGHLY UNDERSTAND THESE INSTRUCTIONS BEFORE INSTALLING RUPTURE DISC. THESE INSTRUCTIONS DO NOT PURPORT TO ADDRESS ALL OF THE SAFETY FACTORS ASSOCIATED WITH THE RUPTURE DISC'S USE IN SERVICE. IT IS THE RESPONSIBILITY OF THE USER TO ESTABLISH APPROPRIATE SAFETY, HEALTH, AND TRAINING MEASURES FOR THEIR PERSONNEL INSTALLING, SERVICING, OR WORKING IN AN AREA WHERE RUPTURE DISC ASSEMBLIES ARE IN USE. SERVICE AND/OR MAINTENANCE ON OR AROUND THE RUPTURE DISC DEVICE MUST NOT BE PERFORMED WHILE THE DEVICE IS SUBJECTED TO OPERATING PRESSURES AND/OR TEMPERATURES.

NOTE: THE CONTINENTAL DISC QUICK-CHANGE RUPTURE DISC ASSEMBLY UTILIZES A HOUSING FOR BOLTING INTO THE RELIEF PIPING AND A RUPTURE DISC CARTRIDGE FOR EASY CHANGEOUT OF RUPTURE DISCS. THE HOUSING IS A PRE-ASSEMBLED UNIT WITH PRE-INSTALLED SEAL RINGS.

IT IS THE USER'S SOLE RESPONSIBILITY FOR DESIGN AND PLACEMENT OF RUPTURE DISCS WITHIN THEIR FACILITY AND UPON THE EQUIPMENT UPON WHICH THE RUPTURE DISC OF USER'S SELECTION IS TO BE LOCATED. IT IS USER'S SOLE RESPONSIBILITY FOR THE DESIGN OF ADEQUATE VENTING AND INSTALLATION OF ADEQUATE VENT PIPING OR DIRECTIONAL FLOW AFTER RUPTURE OCCURS WITH THE RUPTURE DISC AS INTENDED. WHEN SIZE IS SPECIFIED, CONTINENTAL DISC CORPORATION ASSUMES THAT ADEQUATE PROVISIONS HAVE BEEN MADE BY PURCHASER FOR PROPER VENTING OF A SYSTEM TO RELIEVE THE SPECIFIC PRESSURE. LOCATE RUPTURE DISC WHERE PEOPLE OR PROPERTY WILL NOT BE EXPOSED TO THE SYSTEM DISCHARGE IN CASE OF RUPTURE. VENT TOXIC OR FLAMMABLE FUMES OR LIQUIDS TO A SAFE LOCATION TO PREVENT PERSONAL INJURY OR PROPERTY DAMAGE.

IT IS THE USER'S SOLE RESPONSIBILITY TO SPECIFY THE BURST PRESSURE RATING OF A RUPTURE DISC AT A COINCIDENT TEMPERATURE AT WHICH THE RUPTURE DISC IS TO BE USED. A RUPTURE DISC IS A TEMPERATURE SENSITIVE DEVICE. THE BURST PRESSURE OF THE RUPTURE DISC IS DIRECTLY AFFECTED BY ITS EXPOSURE TO THE COINCIDENT TEMPERATURE. GENERALLY, AS THE TEMPERATURE AT THE RUPTURE DISC INCREASES, THE BURST PRESSURE DECREASES; INVERSELY, AS THE TEMPERATURE AT THE RUPTURE DISC DECREASES, THE BURST PRESSURE MAY INCREASE. FAILURE TO PROPERLY UTILIZE A RUPTURE DISC AT THE SPECIFIED COINCIDENT TEMPERATURE COULD CAUSE PREMATURE FAILURE OR OVERPRESSURIZATION OF A SYSTEM.

THE INSTANTANEOUS RELEASE OF PRESSURE FROM THE RUPTURE DISC CAN CREATE VIOLENT NOISES DUE TO THE DISCHARGE AT SONIC VELOCITY. IT IS THE USER'S SOLE RESPONSIBILITY TO PROTECT AGAINST HEARING DAMAGE TO ANY BYSTANDERS.

RUPTURE DISCS AND TAGS ARE MADE OF METAL FOILS OF VARYING THICKNESS. THE METAL EDGES MAY BE SHARP. PERSONNEL INSTALLING OR EXAMINING THE RUPTURE DISCS SHOULD PROTECT AGAINST CUTS OR INJURY WHEN HANDLING THE RUPTURE DISC. DO NOT LIFT A RUPTURE DISC BY ITS ATTACHED TAG.

PARTICLES MAY BE DISCHARGED WHEN THE RUPTURE DISC RUPTURES. THESE PARTICLES MAY BE PART OF THE RUPTURE DISC ITSELF, OR OTHER ENVIRONMENTAL MATTER IN THE SYSTEM. IT IS THE USER'S SOLE RESPONSIBILITY TO ASSURE THAT THESE PARTICLES ARE DIRECTED TO A SAFE AREA TO PREVENT PERSONAL INJURY OR PROPERTY DAMAGE.

THERE IS NO GUARANTEE OF RUPTURE DISC LIFE. SUCH LIFE SPAN IS AFFECTED BY CORROSION, CREEP AND FATIGUE, AND PHYSICAL DAMAGE. THESE CONDITIONS WILL DERATE THE RUPTURE DISC TO A LOWER SET PRESSURE. THE CUSTOMER AND/OR USER SHOULD BE PREPARED TO HANDLE PREMATURE FAILURE OF THE RUPTURE DISC. THE MEDIA OR OTHER ENVIRONMENTAL CONDITIONS SHOULD NOT ALLOW ANY BUILDUP OR SOLIDIFICATION OF MEDIA TO OCCUR ON A RUPTURE DISC. THIS MAY INCREASE THE PRESSURE SETTING OF THE RUPTURE DISC.

CUSTOMER AND/OR ITS INSTALLER SHALL BE SOLELY RESPONSIBLE FOR THE PROPER INSTALLATION OF SELLER'S HOLDERS AND RUPTURE DISCS INTO A SYSTEM. CUSTOMER AND/OR ITS INSTALLER SHALL BE SOLELY RESPONSIBLE FOR IMPROPER INSTALLATION AND PHYSICAL DAMAGE RESULTING THEREFROM, INCLUDING BUT NOT LIMITED TO, DAMAGE RESULTING FROM LEAKAGE, IMPROPER TORQUING OR SEATING OF A RUPTURE DISC OR FAILURE TO FOLLOW INSTALLATION INSTRUCTIONS WHERE PROVIDED.

RUPTURE DISCS ARE PRECISION SAFETY DEVICES AND MUST BE INSTALLED PROPERLY. RUPTURE DISCS MUST BE INSTALLED BY TRAINED, KNOWLEDGEABLE INSTALLERS AND ONLY WITHIN ENVIRONMENTS SUITABLE AND APPROPRIATE FOR A RUPTURE DISC. CARE MUST BE USED IN A FACILITY'S DESIGN TO PROTECT BOTH THE RUPTURE DISC FROM INADVERTENT DAMAGE WHICH COULD CAUSE ITS PREMATURE RELEASE AND TO PROTECT INDIVIDUALS EXPOSED TO HAZARDS CREATED BY SUCH SUDDEN RELEASE.

PROPER INSTALLATION OF A RUPTURE DISC IS CRITICAL TO PERFORMANCE AND TO SAFETY. FAILURE TO PROVIDE PROPER SEATING OF A RUPTURE DISC MAY AFFECT RUPTURE DISC PERFORMANCE, BURST PRESSURE ACCURACY AND MAY RESULT IN ITS PREMATURE FAILURE.

A. INSTRUCTIONS FOR NEW HOUSING AND CARTRIDGE INSTALLATION

I. Safety Precautions Before Installation

1. The exterior sliding surfaces of the cartridge inlet and cartridge outlet have been machined to a very smooth surface for easy cartridge insertion. Use care to not scratch, dent, or otherwise damage these surfaces while assembling or carrying the cartridge unit.
2. Any disassembly or assembly of the cartridge should be done on a clean surface.

II. Quick-Change Housing Installation (See Figure A)

1. Install the housing unit between the vent piping companion flanges using appropriate gasketing at the inlet and outlet mating surfaces. Note that the flow direction arrow points downstream when installing the housing assembly.
2. Thread the studs provided into the blind tapped holes in the inlet and outlet plates of the QUICK-CHANGE housing assembly.
3. Install and torque all nuts using good piping practice, to a torque necessary to seal the gaskets.
4. Remove lockpin from the housing assembly to prepare for installation of the QUICK-CHANGE cartridge.
5. Visually inspect the seal rings in the housing. All contact surfaces should be free of dirt and severe scratches or burrs. Visually inspect the O-rings on the seal ring contact surface to assure integrity of their sealing capabilities. Physically depress the seal rings to ensure freedom of movement.

III. Assembly of the Rupture Disc and Holder (See Figure A)

1. Carefully remove and discard any shipping protectors furnished with rupture discs or cartridge. **DO NOT INSTALL A SHIPPING PROTECTOR IN A QUICK-CHANGE CARTRIDGE.**
2. ENSURE THAT THE RUPTURE DISC DOES NOT EXCEED THE MAXIMUM DISC RATING STAMPED ON THE CARTRIDGE NAMEPLATE. If this condition occurs, consult the factory.
3. Place the cartridge outlet on a clean flat surface with the alignment pins pointing up.
4. Match the notches in the rupture disc with the shape of the pins. Place the rupture disc over the pins with the dome side down.
5. Match the holes in the cartridge inlet with the shape of the pins in the cartridge outlet. Position the cartridge inlet carefully onto the alignment pins as shown, ensuring that the rupture disc is not damaged.
6. Fasten the assembly together by replacing and tightening the cap screws to finger tightness. Using a calibrated torque wrench, torque each cap screw in a cross torquing pattern (See Figure C) to the recommended torque values listed below.

RECOMMENDED TORQUE VALUES

| Size | 1-1/2" | 2" | 3" | 4" | 6" | 8" |
|-------|--------|----|----|----|-----|-----|
| Ft•Lb | 27 | 27 | 30 | 65 | 100 | 120 |
| N•m | 37 | 37 | 41 | 88 | 136 | 163 |

7. After torquing, verify that the horizontal surfaces of the cartridge inlet and the cartridge outlet are parallel to one another.
8. Invert assembled rupture disc and cartridge. Check all flow arrows for proper flow direction.

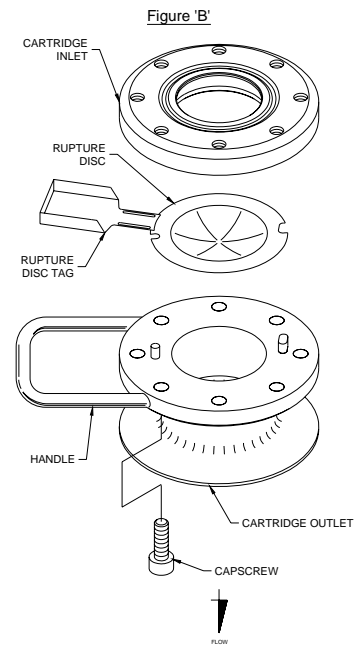
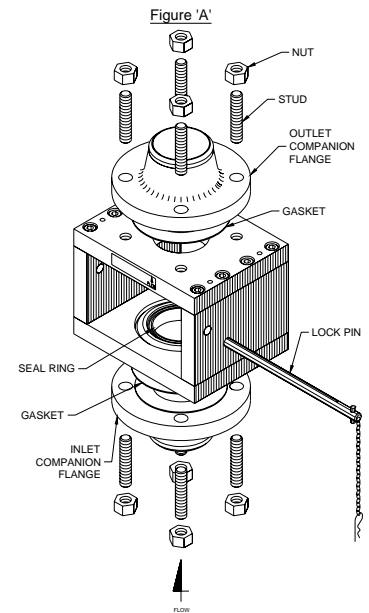
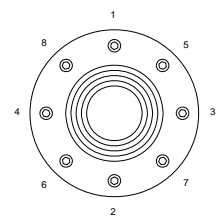

FIGURE 'C'
TOP VIEW OF
CARTRIDGE ASSEMBLY
SHOWING EXAMPLE OF
CAP SCREW TORQUE SEQUENCE



8-CAPSCREWS

IV. Quick-Change Cartridge Installation

1. Visually inspect the cartridge sliding and sealing surfaces to ensure they are clean and free of severe scratches and burrs.
2. Verify that the cartridge flow arrows point downstream and slowly slide the cartridge into the housing, over the seal rings, until the seal rings lock into the cartridge sealing grooves and the cartridge comes into contact with the stop pins. Note: To ease insertion, tilt cartridge up and down slightly while slowly sliding it into the housing. **CAUTION: DO NOT ATTEMPT TO FORCE THE CARTRIDGE ASSEMBLY INTO THE HOUSING. IF DIFFICULTY IS EXPERIENCED, REVERIFY THAT THE HORIZONTAL SURFACES OF THE CARTRIDGE INLET AND CARTRIDGE OUTLET ARE PARALLEL TO ONE ANOTHER AND THAT THE FLOW ARROWS POINT DOWNSTREAM.**
3. Replace the lockpin in the housing.
4. The QUICK-CHANGE unit is now ready for service.

B. INSTRUCTIONS FOR REPLACEMENT RUPTURE DISC INSTALLATION

I. Safety Precautions Before Installation

1. The Composite Type rupture disc is a precision instrument and must be handled with extreme care. Rupture discs should be installed only by qualified personnel familiar with rupture discs and proper piping practices.
2. Do not install rupture disc if there is any damage in the dome area. A damaged rupture disc is any rupture disc with visible nicks or dents in the dome.
3. Continental Disc Corporation does not recommend reinstalling a rupture disc that has been removed from the cartridge as reinstallation may adversely affect the joint sealing capabilities and/or performance of the rupture disc.

II. Preparation of The Cartridge Assembly for Installation

1. Remove the cartridge from the system and place on a clean flat surface.
2. Disassemble the cartridge by removing the cap screws that hold the cartridge inlet and the cartridge outlet together. Lift the cartridge outlet up and set upside down on a flat surface; then remove the burst rupture disc.
3. Clean the rupture disc sealing area of both the cartridge inlet and cartridge outlet. These surfaces must be completely clean and free of all rust, corrosion, and foreign material to ensure a proper seal. Use of solvents, steel wool, or fine emery cloth is permissible. Do not re-machine. Do not use scraper or abrasives.
4. Inspect the rupture disc sealing area for nicks, scratches, or pitting. If any of these conditions are present, consult the factory for repair.

III. Assembly of the Rupture Disc and Cartridge (See Figure D)

1. Carefully remove and discard any shipping protectors furnished with the rupture disc or cartridge. **DO NOT INSTALL A SHIPPING PROTECTOR IN A QUICK-CHANGE CARTRIDGE.**
2. **ENSURE THAT THE RUPTURE DISC DOES NOT EXCEED THE MAXIMUM DISC RATING STAMPED ON THE CARTRIDGE NAMEPLATE.** If this condition occurs, consult the factory.
3. Place the cartridge outlet on a clean flat surface with the alignment pins pointing up.
4. Match the notches in the rupture disc with the shape of the pins. Place the rupture disc over the pins with the dome side down.
5. Match the holes in the cartridge inlet with the shape of the pins in the cartridge outlet. Position the cartridge inlet carefully onto the alignment pins as shown, ensuring that the rupture disc is not damaged.
6. Fasten the assembly together by replacing and tightening the cap screws to finger tightness. Using a calibrated torque wrench, torque each cap screw in a cross torquing pattern (See Figure E) to the recommended torque values listed below.

FIGURE 'E'
TOP VIEW OF
CARTRIDGE ASSEMBLY
SHOWING EXAMPLE OF
CAP SCREW TORQUE SEQUENCE

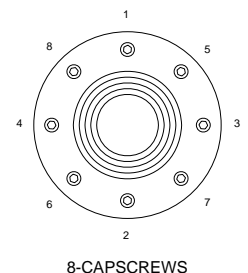

| | RECOMMENDED TORQUE VALUES | | | | | |
|-------|---------------------------|----|----|----|-----|-----|
| Size | 1-1/2" | 2" | 3" | 4" | 6" | 8" |
| Ft•Lb | 27 | 27 | 30 | 65 | 100 | 120 |
| N•m | 37 | 37 | 41 | 88 | 136 | 163 |

7. After torquing, verify that the horizontal surfaces of the cartridge inlet and the cartridge outlet are parallel to one another.
8. Invert assembled rupture disc and cartridge. Check all flow arrows for proper flow direction.

IV. Quick-Change Cartridge Installation

1. Visually inspect the cartridge sliding and sealing surfaces to ensure they are clean and free of severe scratches and burrs.
2. Verify that the cartridge flow arrows point downstream and slowly slide the cartridge into the housing, over the seal rings, until the seal rings lock into the cartridge sealing grooves and the cartridge comes into contact with the stop pins. Note: To ease insertion, tilt cartridge up and down slightly while slowly sliding it into the housing. **CAUTION: DO NOT ATTEMPT TO FORCE THE CARTRIDGE ASSEMBLY INTO THE HOUSING. IF DIFFICULTY IS EXPERIENCED, REVERIFY THAT THE HORIZONTAL SURFACES OF THE CARTRIDGE INLET AND CARTRIDGE OUTLET ARE PARALLEL TO ONE ANOTHER AND THAT THE FLOW ARROWS POINT DOWNSTREAM.**
3. Replace the lockpin in the housing.
4. The QUICK-CHANGE unit is now ready for service.

C. MAINTENANCE INSTRUCTIONS

I. Preventative Maintenance (See Figure F)

1. Every six months, or sooner if process conditions merit, remove the top and bottom seal rings. Inspect both O-rings for severe deformation, nicks, etc. Replace as necessary. The following should be checked:

HOUSING ASSEMBLY:

- 1) Check the angled sliding surface and the surfaces of the O-ring groove area of the seal rings for corrosion, burrs, scratches, etc. If present, lightly sand these smooth with fine grit emery cloth.
- 2) Check the wave springs for corrosion or loss of resilience.
- 3) Check the contact surfaces on the inlet plate and the outlet plate on which the Inlet/Outlet O-rings (Housing) ride, for corrosion, pitting or product buildup. If present, lightly sand these surfaces clean with fine grit emery cloth. Lubricate these surfaces and the O-rings with petroleum jelly before reinstalling the seal rings.
- 4) Check for corrosion on the exterior surfaces of the housing. If necessary, wire-brush clean.

CARTRIDGE ASSEMBLY:

- 5) Check the cartridge sealing surfaces for product buildup, scratches, burrs, etc. If present, lightly sand these surfaces smooth with fine grit emery cloth.
- 6) Check for corrosion on the exterior surfaces of the cartridge unit. If necessary, wire-brush clean.

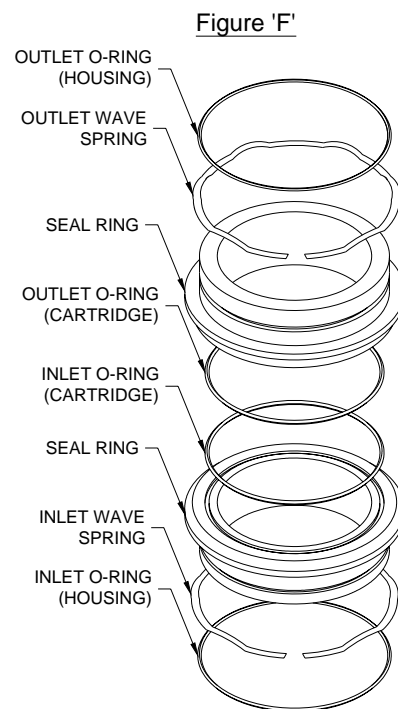

2. Risk assessment and an annual rupture disc replacement are recommended. Rupture disc service life is determined by system operating conditions. The effects of severe pressure/vacuum cycles, corrosion, temperature variations, or other adverse conditions must be evaluated by the user through actual service experience to determine optimal service life.
3. **IF THE RUPTURE DISC IS NOT REPLACED PERIODICALLY WHEN EXPOSED TO THESE CONDITIONS, PREMATURE FAILURE OF THE RUPTURE DISC MAY OCCUR, THEREBY DISCHARGING THE PROCESS MEDIA.**
4. To avoid extended downtime, maintain three spare rupture discs in stock at all times for each cartridge in use. The number of spares required ultimately will be determined by service conditions.

II. Replacement Parts**

1. Inlet/Outlet O-Ring (Housing)
2. Inlet/Outlet O-Ring (Cartridge)
3. Inlet/Outlet Wave Spring

D. Customer Service

If you wish to discuss your application, installation, or maintenance, please contact the Customer Service Department at one of the addresses shown on the last page of these instructions.

****Specify Size, Class and Material when ordering.**

COMPOSITE Type Rupture Disc incorporates U.S. Patent No.: 3,445,032.

QUICK-CHANGE incorporates U.S. Patent No.'s: 4,444,214 and 4,505,289; Canada Patent No.: 1,172,936; West Germany Patent No.: P.3174255.6-08; France, Belgium and Great Britain Patent No.: 0065050; Japan Patent No.: 1,370,132



**Continental Disc[®]
Corporation**

Performance Under Pressure[®]



Certified Quality System
First Certified In 1992



ASME Code Symbol Stamp
If stamped, this product is built in accordance with the requirements of the ASME Boiler and Pressure Vessel Code, Section VIII, Division 1.

China Manufacture License
Products are in full compliance with the provisions of the People's Republic of China Import Regulations for Boiler and Pressure Vessel safety devices.



3A Sanitary Standards Stamp
If stamped, this product is in full compliance with the 3A standards, Serial #60-00, of the International Association of Milk, Food, and Environmental Sanitarians, Inc.



**European Union CE Mark
Type Approval Stamp**
If stamped, this product is certified to conform to the essential requirements of the Pressure Equipment Directive.

Continental Disc Corporation has representatives located throughout the world.
Contact the C.D.C. office nearest you for the authorized representative in your area.

CORPORATE HEADQUARTERS

Continental Disc Corporation

3160 W. Heartland Drive
Liberty, Missouri 64068-3385 USA
Phone: (816) 792-1500
FAX: (816) 792-2277 / 5447
E-mail: pressure@contdisc.com
Website: www.contdisc.com

THE NETHERLANDS

Continental Disc Corporation
Energieweg 20
2382 NJ Zoeterwoude-Rijndijk
The Netherlands
Phone: +(31) 71-5412221
FAX: +(31) 71-5414361
E-mail: c dcnl@contdisc.com

UNITED KINGDOM

Continental Disc UK Ltd
Unit C, The Business Centre
Faringdon Avenue, Harold Hill
Romford, Essex RM3 8EN
United Kingdom
Phone: +(44) 1708-386444
FAX: +(44) 1708-386486
E-mail: c duk@contdisc.com

CHINA

Continental Disc Corporation
Room 910, Tower B, COFCO Plaza
No. 8 JianGuoMenNei Avenue
Beijing (100005)
P.R. China
Mobile: +(86) 137 0103 8871
E-mail: c dcchina@contdisc.com

DUBAI

Continental Disc Corporation
P. O. Box 2234
Dubai, U.A.E.
Phone: +(971) 43214490
Fax: +(971) 43438840
Mobile: +(971) 508129525
E-mail: kannan@contdisc.com