

VRD[®] Reverse Acting Rupture Disc Assembly

3-2230-3



**Continental Disc[®]
Corporation**

Performance Under Pressure[®]

Water Storage Tank

to MR-10 (605)

FOR FIXED PIPING ARRANGEMENTS

When Size Matters

Introducing the VRD® Reverse Acting Rupture Disc Assembly. This all-new rupture disc and holder system combines all the benefits of our scored, reverse acting line of rupture discs with the additional feature of a reduced holder height. You now have the flexibility of using our reverse acting rupture discs in existing fixed piping systems.

The VRD Assembly is available in a wide variety of sizes, materials, and pressure ranges. The specifications for the standard VRD Assembly can be found on pages 4-5. For information on applying the VRD to applications outside these specifications, consult the C.D.C. corporate headquarters or your local C.D.C. representative. Our experienced *Tech Team* is available to assist you with your system requirements.

Reduced Height Stretches Application Flexibility

The VRD Rupture Disc Assembly uses our patented reverse acting disc technology with a holder designed with a shorter overall height, to allow a fit (or retrofit) into existing fixed piping systems. The height dimension for the VRD Assembly can be found in Table III.

Gaseous and Liquid Service

The VRD Assembly is designed to provide full opening, even in non-compressible liquid applications. Below certain set pressures, the user should consult the factory about applying the VRD Rupture Disc in liquid systems. Consult Table I for a listing of sizes and set pressures.

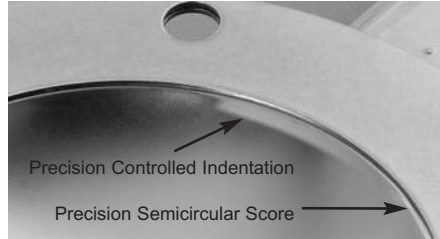

Precise Setting/Optimum Flow

The VRD Rupture Disc incorporates patented* *precision controlled indentations*. These features allow precise control of burst pressure in a reverse acting rupture disc.

The VRD Rupture Disc uses a semicircular score to provide a clean, consistent opening pattern in a non-fragmenting design. At burst, the score pattern allows the disc to fully open, folding back against the holder, resulting in an optimum flow condition.

Seal Load Sensitivity

Overtorquing will not affect the burst accuracy of the VRD Rupture Disc.

The VRD Rupture Disc is supplied with permanently attached encapsulating rings, which are proven to eliminate seal load (bolt torque) sensitivity. These encapsulating rings provide the following benefits:

- Assure proper location of the rupture disc in the holder,
- Prevent rupture disc slippage when insufficient bolt load is applied to the companion flanges,
- Provide a base to accept reasonable overtorquing of the companion flange bolts while protecting the rupture disc from being damaged, and
- Provide a superior metal-to-metal seal surface.

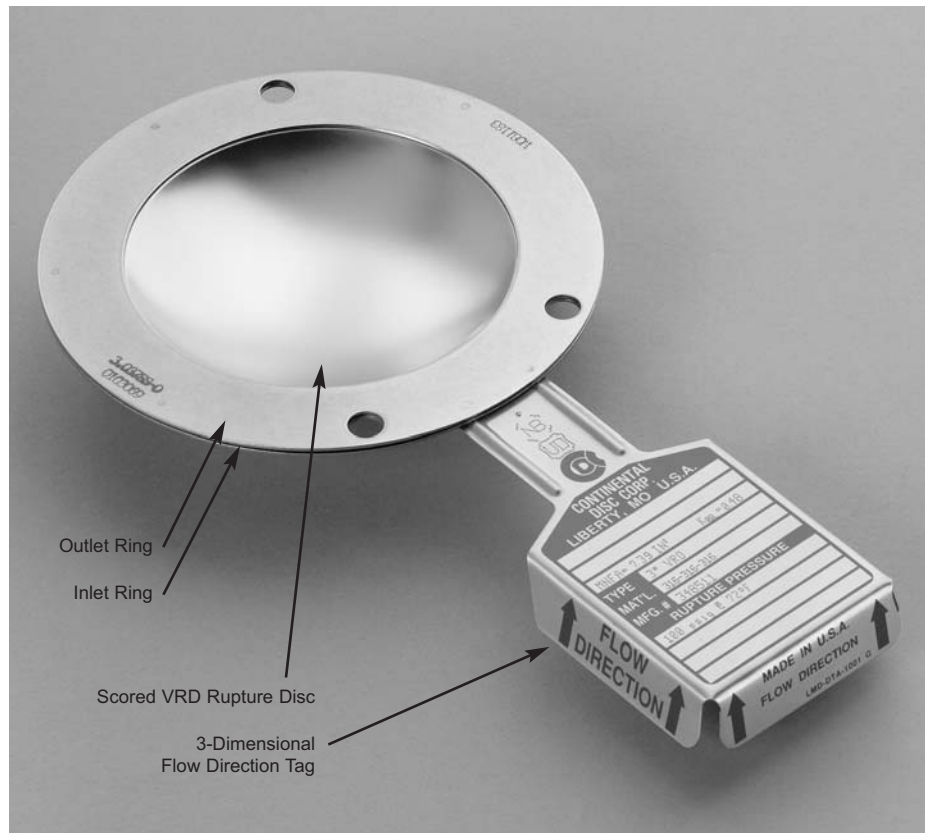

* VRD Rupture Disc incorporates United States patent no. 4,597,505; 4,512,171; 4,072,160; 4,669,626 and 4,759,460; Australia patent no. 579833; Canada patent no. 1244315; Chile patent no. 35096; Germany patent no. P 3473633.6; France, Netherlands and United Kingdom patent no. EP 0 137 903; India patent no. 160204; Ireland patent no. 55493; Mexico patent no. 161587; Spain patent no. 289581; and Venezuela patent no. 46.640.

Zero Manufacturing Range/ 90% Operating Pressure

As a standard, the VRD Rupture Disc is designed with a zero manufacturing range. This enables system operation up to 90% of the rated (marked) burst pressure for burst pressure settings of 40 psig and above.

For rated burst pressures below 40 psig, the recommended maximum operating pressure is 90% of the value of the rated (marked) burst pressure minus the burst tolerance (i.e.: max. operating pressure = [marked rating minus 2 psig burst tolerance] x 0.90).

Safety Ratio

The VRD Rupture Disc is designed and tested to have a safety ratio of 1.5 or less. This means that should your VRD Rupture Disc be damaged during handling or installation, it is designed to provide pressure relief at or less than 1.5 times the rated (marked) burst pressure of the rupture disc.

Vacuum Conditions

When a system vacuum occurs due to product evacuation, steam cleaning, or other factors, the VRD Rupture Disc is designed to withstand full vacuum without failing or affecting the burst pressure setting or reliability. This feature is inherent with most reverse acting types of rupture discs on the market. No additional components, such as a vacuum support, are required.

Corrosive Protection

The VRD Rupture Disc is superior for use in a corrosive media or environment. Versatile material selection and use of thicker rupture disc materials contribute to the superior corrosive resistance. A Teflon®* liner or Teflon coating may be used on the process side of the VRD Rupture Disc for additional corrosion protection.

Tagging

The VRD Holder is supplied with a permanently attached stainless steel nameplate with arrows that indicate flow

direction. In addition, the VRD Rupture Disc is supplied with a 3-Dimensional Flow Direction Tag. Directional arrows on both the tag and nameplate provide a means to visually verify the rupture disc assembly is properly oriented in your system. In accordance with customer specifications, pertinent identification information will be stamped on the rupture disc holder and tags.



B.D.I.® (Burst Disc Indicator) Alarm System**

Where immediate notification of pressure relief is required, Continental's patented B.D.I. (Burst Disc Indicator) Alarm System should be used. Designed for use with Continental's rupture discs, the B.D.I. Alarm System automatically notifies the operator, via audio and/or visual warnings, that a rupture disc has burst.

The heart of the B.D.I. Alarm System is the alarm strip. The alarm strip is attached to a flat Teflon membrane and assembled between non-asbestos gaskets. It is installed downstream from the rupture disc between the outlet side of the holder and the pipe flange.



When the rupture disc bursts, the strip is broken, disrupting the electrical current through the strip and activating the alarm monitor. The B.D.I. Alarm is resistant to most corrosives and can operate at temperatures ranging from -40°F to 400°F (-40°C to 206°C).

It is available with Factory Mutual approved, intrinsically safe monitors, and is computer compatible.

* Teflon is a registered trademark of E.I. du Pont de Nemours and Company used under license.

** Burst Disc Indicator (B.D.I.) Alarm System incorporates United States patent no. Re.34,308 and 4,408,194; Australia patent no. 539415; Canada patent no. 1199990; Germany patent no. 3174227.0; Japan patent no. 2032464; Belgium, France and United Kingdom patent no. EP 0 033 867.

SPECIFICATIONS

Table I – VRD Minimum / Maximum Burst Pressures at 72°F (22°C)

White bars indicate psig. Gray bars indicate barg.

Nominal Size	Rupture Disc Materials								
	Nickel / Monel**			316 Stainless Steel / Inconel**			Hastelloy C276***		
	Minimum	Minimum For Liquid Service As Standard	Maximum	Minimum	Minimum For Liquid Service As Standard	Maximum	Minimum	Minimum For Liquid Service As Standard	Maximum
1 in	20	100	1000	20	125	1000	40	140	1000
25 mm	1,38	6,89	68,9	1,38	8,62	68,9	2,75	9,66	68,9
1-1/2 in	16	85	900	16	100	1000	30	110	1000
40 mm	1,10	5,86	62,0	1,10	6,89	68,9	2,07	7,95	68,9
2 in	15	65	850	15	85	900	25	95	1000
50 mm	1,03	4,48	58,6	1,03	5,86	62,0	1,72	6,55	68,9
3 in	15	50	750	15	70	900	22	80	1000
80 mm	1,03	3,44	51,7	1,03	4,82	62,0	1,52	5,52	68,9
4 in	15	50	650	15	60	800	22	70	900
100 mm	1,03	3,44	44,8	1,03	4,13	55,1	1,52	4,83	62,0
6 in	13	40	400	13	50	450	20	60	500
150 mm	0,896	2,75	27,5	0,896	3,44	31,0	1,38	4,74	34,4
8 in	20	40	250	25	50	300	35	60	350
200 mm	1,38	2,75	17,2	1,72	3,44	20,6	2,41	4,14	24,1

Table II – VRD Temperature Limits

Rupture Disc Material	Recommended Temperature	
	Fahrenheit	Celsius
Nickel	800°	427°
Monel	800°	427°
316 Stainless Steel	900°	482°
Inconel	1000°	538°
Hastelloy C-276	900°	482°
Teflon Liner	500°	260°

NOTE:

1. "Minimum For Liquid Service As Standard" is the lowest pressure at which the particular size and material rupture disc is designed to open fully under liquid pressure at 72°F (22°C) as a standard. There will be an additional testing charge for rupture discs rated below this pressure which are intended for use in liquid systems.
2. Below the "Minimum For Liquid Service As Standard" pressure, Teflon liners may not be available. In this case, a Teflon coating can be applied. Consult the factory.
3. Minimum pressures in Table I are based upon the minimum of any specified manufacturing range at 72°F (22°C).
4. Rupture disc encapsulating rings of stainless steel are standard. For other materials, consult your Continental Disc representative or the factory.
5. For availability of rupture disc materials not listed, consult your Continental Disc representative or the factory.

Manufacturing Range

As a standard, the VRD Rupture Disc is designed with a zero manufacturing range. This enables the disc to operate up to 90% of the customer's specified rating. For systems not required to operate to 90% of the specified burst pressure, other ranges are available upon request. Available ranges include: -2.5 psig or -5 psig for burst pressure ratings below 50 psig and -5% or -10% for burst pressures 50 psig and above.

Burst Tolerance

The VRD Rupture Disc is designed with a burst tolerance of ± 2 psig for pressures up to and including 40 psig, and $\pm 5\%$ for pressures above 40 psig. The rated burst pressure, appearing on the rupture disc tag, is established as follows:

- For zero manufacturing range rupture discs, a minimum of two burst tests per lot of rupture discs are conducted to determine conformance with the customer's specified burst pressure. The rated burst pressure appearing on the tag

will be the customer's specified burst pressure. The burst tolerance of $\pm 5\%$ applies to the rated burst pressure.

- For rupture discs with -5%, -10%, -2.5 psig or -5 psig manufacturing ranges, the rated burst pressure is established by bursting a minimum of two discs per lot and averaging the actual burst results. This average burst pressure is the rated (marked) burst pressure which will appear on the rupture disc tag. The burst tolerance of $\pm 5\%$ applies to the rated (marked) burst pressure.

* Monel and Inconel are registered trademarks of the Inco family of companies.

** Hastelloy is a registered trademark of Haynes International.

VRD Holder

The VRD Holder is an insert type holder. It has been designed for ease of assembly and superior sealing capability. Alignment of the VRD Rupture Disc and flow direction orientation are provided by round offset pins located in the holder inlet and matching holes in the rupture disc rings.

A tapered, raised seat on the inlet holder provides uniform load on the rupture disc, insuring a metal-to-metal leak-tight seal between the disc and holder.

The rupture disc and holder parts are pre-assembled using pre-assembly clips. As a standard, a J-Hook is provided for easy alignment and proper orientation relative to flow direction.

Holder Specifications

Holders are available for ANSI, JIS or DIN class flanges as shown in Table III. Consult the factory for holders to fit other national or international standards.

MATERIALS: VRD Holders are machined from investment castings of standard materials including Carbon Steel, 316 SS, Monel and Hastelloy-C. Other materials available upon request.

OPTIONS: Holders are available with options including 1/4", 3/8", 1/2" gauge tap (dependent on holder size); nipple and tee; excess flow valve; pressure gauge; special facings; Teflon coating; tantalum lining. Consult the factory for more information.

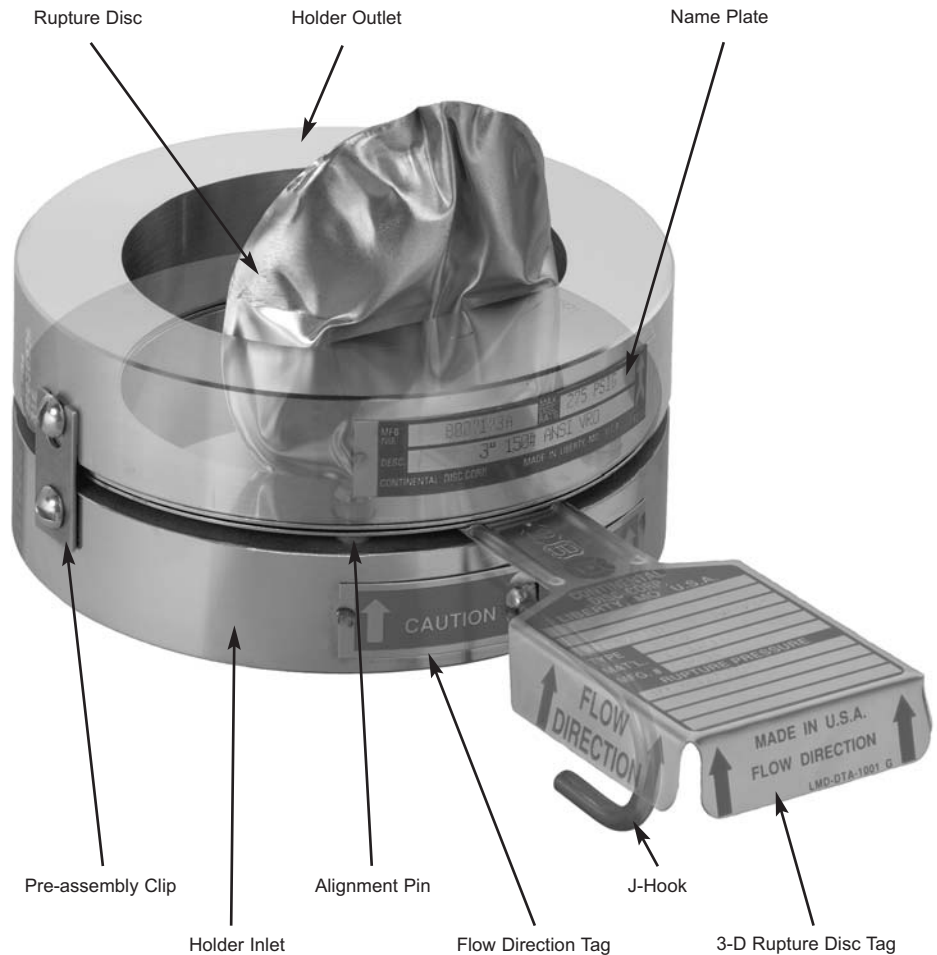

Code Compliance

Continental Disc Corporation will provide rupture discs to national or international code requirements when specified by the customer.

C.D.C. will manufacture, temperature test and mark rupture discs in compliance with the requested code. Product may be supplied to ASME Section III or VIII, EN, DIN, BSI, JIS or other codes as required.

Continental Disc Corporation has been accredited and is authorized by the ASME Code to utilize the  Code Symbol Stamp for product built in accordance with the requirements of the ASME Boiler and Pressure Vessel Code, Section VIII, Division 1.

The VRD Rupture Disc flow performance was certified by The

National Board of Boiler and Pressure Vessel Inspectors. These certified flow resistance (K_R) and minimum net flow area values are available from Continental Disc Corporation or The National Board of Boiler and Pressure Vessel Inspectors.

CE marked VRD Rupture Discs, in accordance with Pressure Equipment Directive 97/23EC, are available when specified.

Continental Disc Corporation maintains an ASME accepted flow laboratory to conduct flow testing for rupture discs, relief valves, and rupture disc/valve combinations.



Each lot of rupture discs manufactured by Continental Disc Corporation is furnished with a Burst Certificate, providing burst test information.

VRD HOLDER

Holder Specifications

VRD Holders are available for ANSI, DIN, JIS class flanges as shown in Table III. Consult the factory for holders to fit other national or international standards.

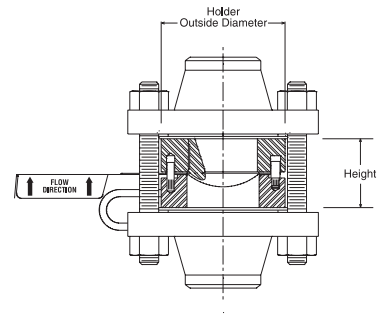

Table III – VRD Insert Holder Dimensions and Weights

Nominal Size	ANSI		DIN		JIS		Height (in / mm)	Weight (lbs / kg)
	Class	Outside Diameter in / mm	Class	Outside Dia. mm	Class	Outside Dia. mm		
1 in 25 mm	150	2.50 / 63,5					1.50 / 38	1.5 / 0,7
	300 / 600	2.75 / 69,9	10 / 40	69,9	10 / 20	69,9	1.50 / 38	1.9 / 0,9
					30 / 40	76,0	1.50 / 38	2.4 / 1,1
1-1/2 in 40 mm	150	3.25 / 82,6					1.70 / 43	2.7 / 1,2
	300 / 600	3.63 / 92,2	10 / 40	92,2			1.70 / 43	3.7 / 1,7
					10 / 20	86,0	1.70 / 43	3.0 / 1,4
	900 / 1500	3.75 / 95,3			30 / 40	97,0	1.70 / 43	4.2 / 1,9
2 in 50 mm	150	4.00 / 101,6			10	101,6	1.83 / 46	4.0 / 1,8
					16 / 20	101,6	1.83 / 46	4.0 / 1,8
	300 / 600	4.25 / 108,0	10 / 40	108,0			1.83 / 46	4.9 / 2,2
					30 / 40	111,0	1.83 / 46	4.9 / 2,2
	900 / 1500	5.50 / 139,7	64	111,0			1.83 / 46	5.3 / 2,4
3 in 80 mm	150	5.25 / 133,4			10	132,0	2.19 / 56	8.0 / 3,6
					16 / 20	137,0	2.19 / 56	8.3 / 3,8
	300 / 600	5.75 / 146,1	10	142,0			2.19 / 56	9.0 / 4,1
			16 / 40	142,0			2.19 / 56	9.0 / 4,1
			64	146,1	30 / 40	146,1	2.19 / 56	11.0 / 5,0
4 in 100 mm					10	156,0	2.90 / 74	12.0 / 5,4
			10 / 16	162,0	16 / 20	162,0	2.90 / 74	13.9 / 6,3
			25 / 40	168,0	30	168,0	2.90 / 74	15.9 / 7,2
	150	6.75 / 171,5					2.90 / 74	17.0 / 7,7
	300	7.00 / 177,8					2.90 / 74	19.5 / 8,8
6 in 150 mm							2.52 / 64	21.8 / 9,9
	150	8.63 / 219,2	10 / 16	217,0	10	217,0	3.64 / 92	28.1 / 12,7
			25 / 40	223,0			3.64 / 92	30.3 / 13,7
	300	9.75 / 247,7			16 / 20	235,0	3.64 / 92	37.4 / 17,0
	600	10.38 / 263,7			30	247,7	3.64 / 92	45.2 / 20,5
8 in 200 mm					40	262,0	3.64 / 92	54.5 / 24,7
							3.08 / 78	48.2 / 21,9
	150	10.88 / 276,4	10	272,0	10	267,0	3.77 / 96	37.1 / 16,8
			16	272,0			3.77 / 96	44.2 / 20,0
					16 / 20	280,0	3.77 / 96	44.2 / 20,0
	300	12.00 / 304,8	25	283,0			3.77 / 96	46.4 / 21,0
		40	290,0			3.77 / 96	49.0 / 22,2	
						3.77 / 96	54.5 / 24,7	
						3.77 / 96	66.3 / 30,1	

NOTE: Consult the factory for availability of flange classes not listed.

To assure selection of the correct rupture disc and holder for your application, please determine:

Specifications:

- 1. Quantity
- 2. Size
- 3. Type
- 4. Materials
- 5. Options (linings, coatings, B.D.I.)
- 6. Specified pressure/specified temperature
- 7. Manufacturing range: zero, -5%, -10% ; -2.5 psig, -5 psig

Quality Assurance/ Documentation:

- 1. Codes: ASME, EN, DIN, JIS, BSI or others
- 2. Special cleaning
- 3. Special packaging
- 4. Special tagging
- 5. Temperature testing
- 6. Material test reports
- 7. Other

Operating Specifications:

- 1. Maximum allowable working pressure (vessel M.A.W.P.)
- 2. Operating pressure
- 3. Operating temperature
- 4. Vacuum/backpressure
- 5. Cycle conditions
- 6. Flow rate required
- 7. Media
- 8. Previous manufacturing number (if known)

Please supply the following when ordering:

RUPTURE DISC: Quantity: _____ **Size:** _____ **Description: VRD Rupture Disc**

Material: _____ Inlet and Outlet Rings: 316 SS¹

Manufacturing Range: Zero²

Rated Burst Pressure: _____ psig or barg @ _____ °F or °C

Burst Tolerance: ± 5% for pressures above 40 psig (2,75 barg);
± 2 psig (0,138 barg) for pressures up to and including 40 psig

Manufacturing Number: _____ for previously supplied rupture discs

Options — Code Compliance: _____

Teflon Liner or Coating: Inlet _____

Protective Cover: Outlet _____

B.D.I. Alarm System: _____

Other requirements: _____

HOLDER: Quantity: _____ **Size:** _____

Description: VRD Holder with J-Hook, to mate with _____³ class flanges

Material: Inlet _____ Outlet _____

Options — Accessories: Gauge Tap / Nipple and Tee / Excess Flow Valve / Pressure Gauge
Special Facing / Tantalum Lining / Teflon Coating

Other requirements: _____

Customer ID Tag: _____

Notes:
1. 316 SS is standard. Specify other material when required.
2. Zero (0) manufacturing range is standard. Other ranges are available; see page 4.
3. Specify class of flange that holder is to mate with, i.e., ANSI 150 or DIN 10/40, etc.

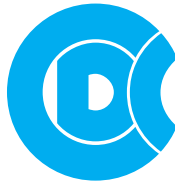

**Continental Disc®
Corporation**

Performance Under Pressure®



Certified Quality System
First Certified In 1992



ASME Code Symbol Stamp
Available When Specified

China Manufacture License
Available When Specified



Pressure Equipment Directive
Available When Specified

Continental Disc Corporation has representatives located throughout the world.
Contact the C.D.C. office nearest you for the authorized representative in your area.

CORPORATE HEADQUARTERS

Continental Disc Corporation
3160 W. Heartland Drive
Liberty, Missouri 64068-3385 USA

Phone: (816) 792-1500
FAX: (816) 792-2277 / 5447
E-mail: pressure@contdisc.com
Website: www.contdisc.com

THE NETHERLANDS

Continental Disc Corporation
2382 NJ Zoeterwoude-Rijndijk
The Netherlands

Phone: +(31) 71-5412221
FAX: +(31) 71-5414361
E-mail: cdcnl@contdisc.com

DUBAI

Continental Disc Corporation
P.O. Box 2234
Dubai, U.A.E.

Phone: +(971) 4 3214490
FAX: +(971) 4 3438840
Mobile: +(971) 50 8129525
E-mail: kannan@contdisc.com

CHINA

Continental Disc Corporation China
Room 910, Tower B, COFCO Plaza
No.8 JianGuoMenNei Avenue,
Beijing (100005)
People's Republic of China

Mobile: +(86) 137 01038871
E-mail: cdcchina@contdisc.com

UNITED KINGDOM

Continental Disc UK Ltd.
Unit C, The Business Centre
Faringdon Avenue, Harold Hill, Romford,
Essex RM3 8EN
United Kingdom

Phone: +(44) 1708-386444
FAX: +(44) 1708-386486
E-mail: cduk@contdisc.com